

# JS 型彈簧式避震器安裝說明

## JS spring isolator installation guide

安裝前，請確認避震器之型號規格是否正確。

Before installation, make sure the model and the specification are correct.

### 安裝說明

### Installation guide

- 所需工具：公制口徑19mm (M12)、24mm (M16)、32mm (M22) 開口扳手、爪式千斤頂。

Required tools: 19mm (M12), 24mm (M16) and 32mm (M22) open wrenches and claw jack.

- 在未完成避震器高度調整前，請勿將避震器之壓墊取出。

Before completing the adjustment of the isolator, do not remove the pressure pad from the isolator.

- 請先依據基礎螺栓固定孔的位置，於安裝位置預埋基礎螺栓。

Embed foundation bolt according to the location of bolt-loaded holes.

- 避震器安放於安裝位置後，先將定位鉚釘拿掉。(如圖1)

Remove quilting rivet after installing the isolator (Fig 1).

- 以M12固定螺栓將避震器與設備固定，但不鎖緊。(如圖2)

Fasten the isolator and the equipment with M12 fixed bolt without locking it (Fig 2).

- 將避震器利用基礎螺栓固定於地面上，並以臨時木台固定高度。

Fasten the isolator with foundation bolt on the ground and fix the height with wooden panel.

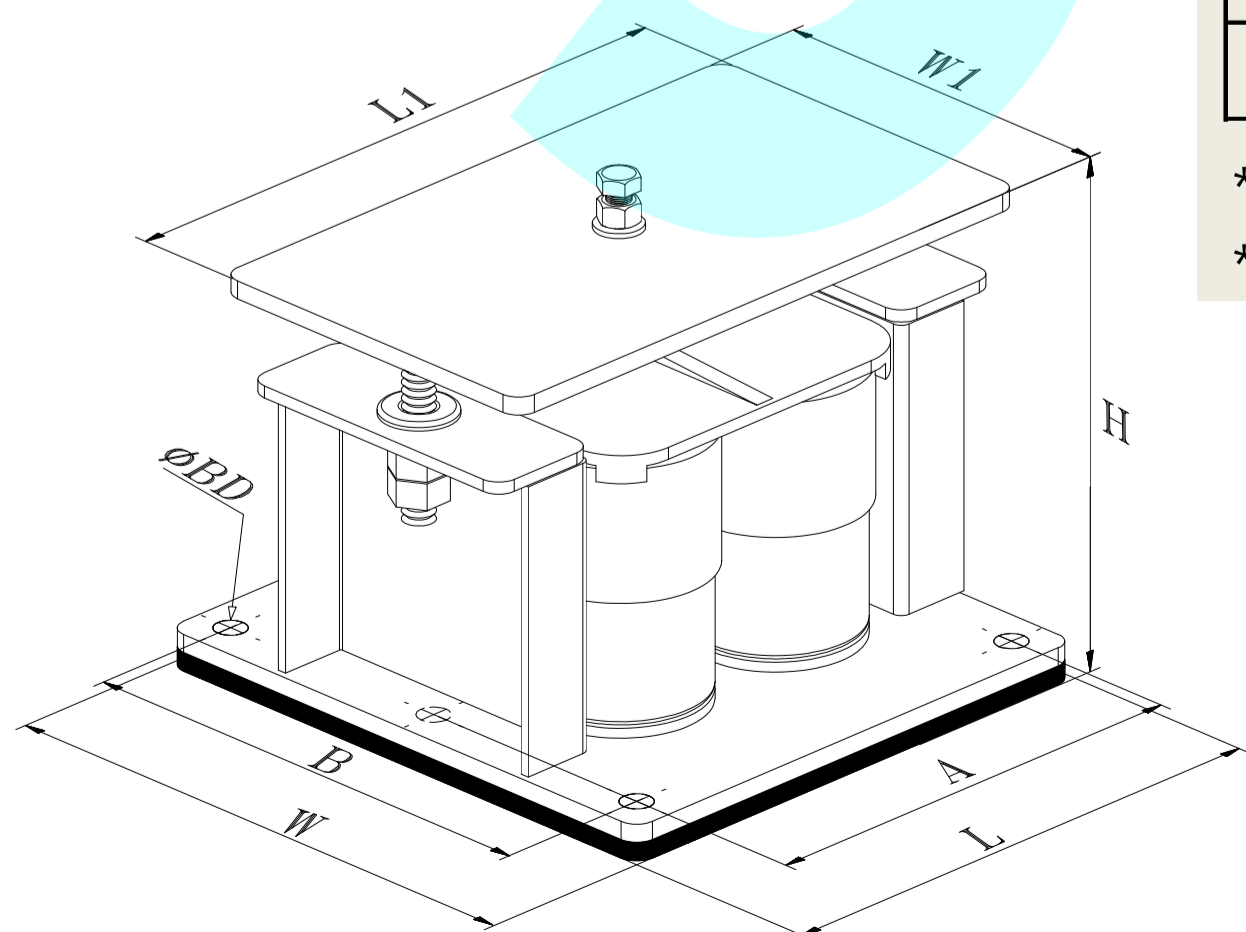

型號 Type	尺寸 Dimension (mm)								固定螺栓 Fixed bolt
	L	W	L1	W1	A	B	H	ψBD	
JS-1	260	100	210	100	230	0	195	16	M12
JS-2	205	220	205	125	165	180	200	16	
JS-4	280	260	320	190	240	220	200	16	

\*B值為0表孔中心在 W/2

\* When B value is 0, the center of the hole is at w/2.

## JS 型彈簧式避震器安裝說明 JS spring isolator installation guide

- 調整避震器高度時先鬆脫兩旁之反擊螺帽5~10mm，並相對鎖固之。

(如圖3)

Loosen the nuts on both sides for 5~10mm first before adjusting height of the isolator and lock them afterwards (Fig 3).

- 使用公制口徑32mm 開口扳手以逆時針方向調整M22螺栓，使彈簧受力下壓、避震器上蓋鐵上升。(如圖4)

Adjust M22 adjustment bolt in the anti-clockwise direction with 32mm open wrench to press down the spring and to raise the iron sheet (Fig 4).

- 調整至壓墊可取出時，即可停止調整並取出木台。(如圖5)

Adjustment can be stopped and wooden panel can be removed once you can take out the pressure pad (Fig 5).

- 將與設備固定之M12螺栓完全鎖緊，即完成安裝調整。(如圖6)

After the adjustment, lock the isolator with M12 fixed bolt (Fig 6).

- 安裝後請檢查彈簧之下壓量，如彈簧壓實表示荷重不足無避震效果。應予更換較大荷重之規格，並請洽本公司業務人員。

After the adjustment, check the press amount of the spring. If it appears with insufficient loading, please replace with bigger loading by contacting our staff.

- 安裝時，請注意安全。

Be cautious during the installation.

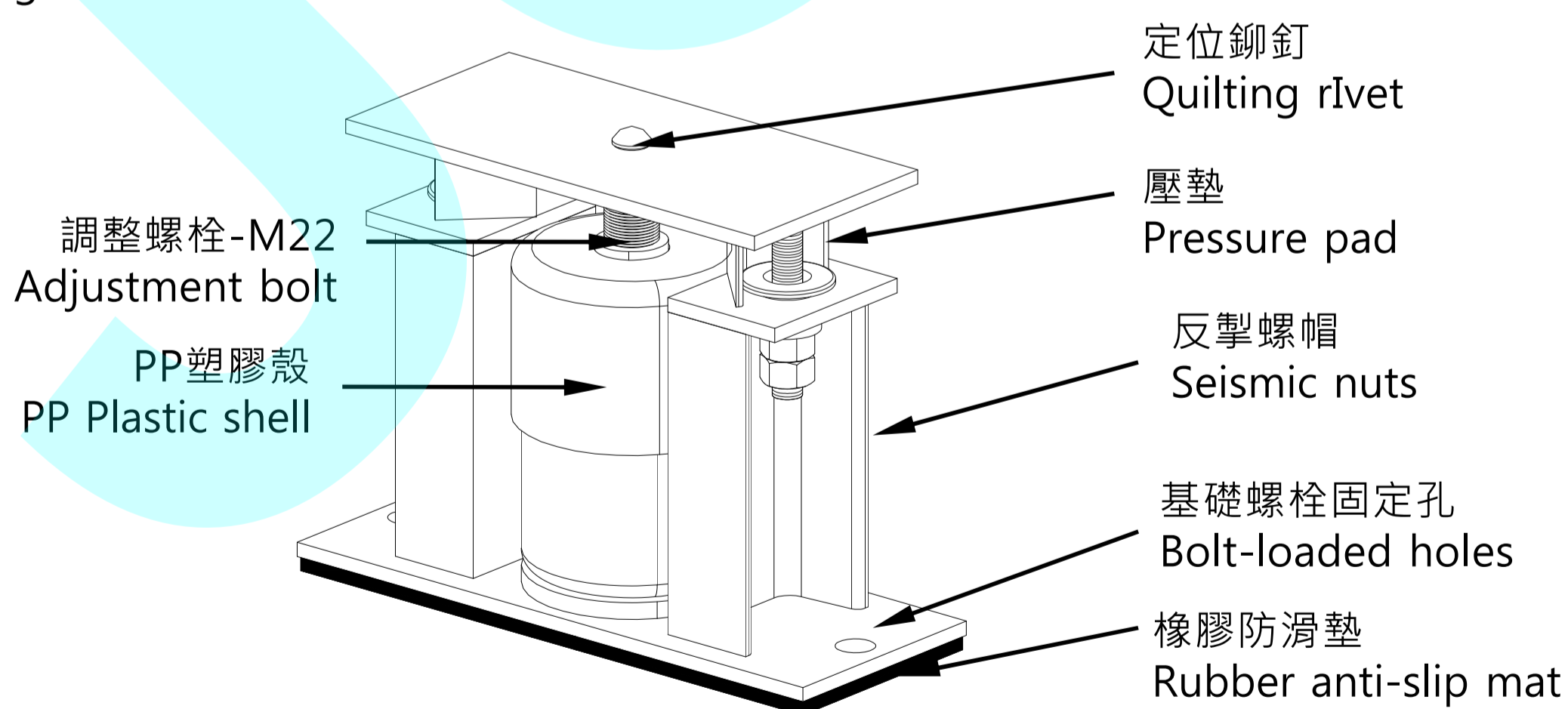

※保養點檢項目：每月觀察固定螺栓&基礎螺栓保持鎖固、保持避震器安裝狀態&彈簧下壓撓度正常。

Maintenance checking points: Check the mounting bolts, remain fixed bolt locked, installation of the isolator, and the deflection of the spring.



# JS 型彈簧式避震器圖解說明 JS spring isolator illustration



圖1) 將定位鉚釘取出，並以木台固定高度。  
Fig 1) Remove quilting rivet and fix the height with wooden panel.

圖2) 以M12螺栓將避震器與設備固定，但不鎖緊；同時以基礎螺栓將避震器固定。  
Fig 2) Fasten the isolator and the Equipment with M12 fixed bolt without locking it. Fasten the isolator with foundation bolt.



圖3) 調整避震器高度時，先鬆脫兩旁之反擊螺帽5~10mm，並相對鎖固之。  
Fig 3) Loosen the nuts on both sides for 5~10mm first before adjusting height of the isolator and lock them afterwards.

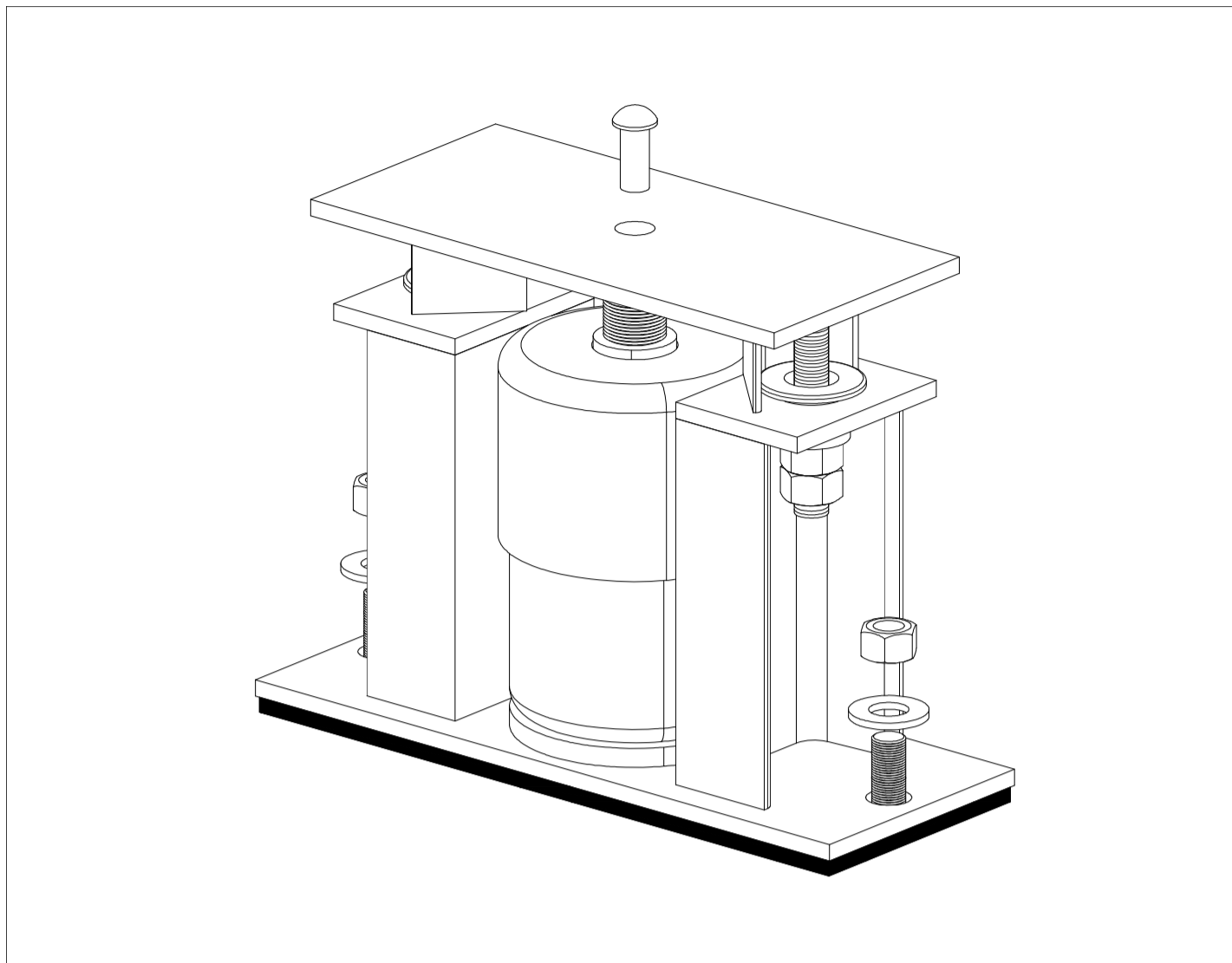

## JS 型彈簧式避震器圖解說明 JS spring isolator illustration

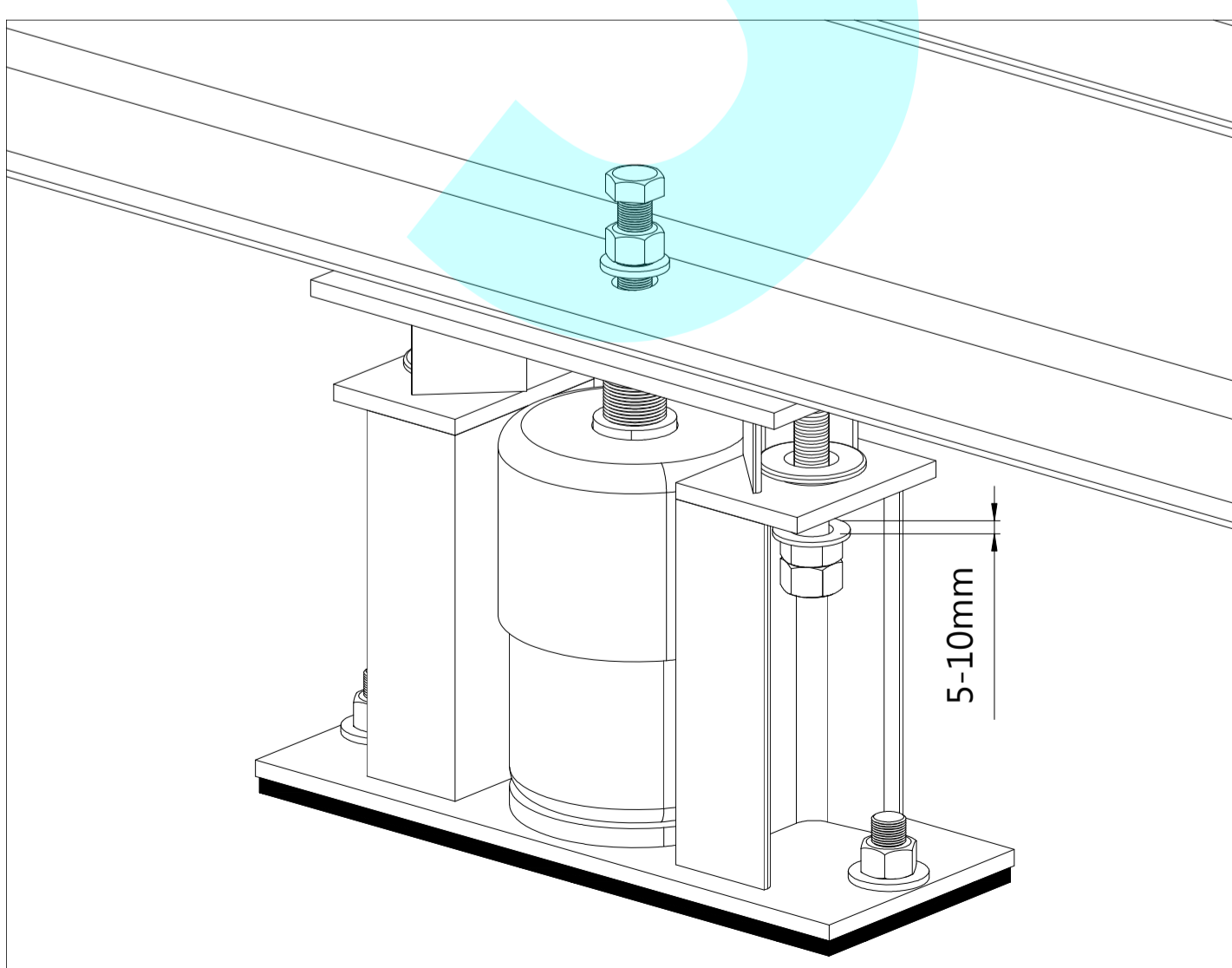
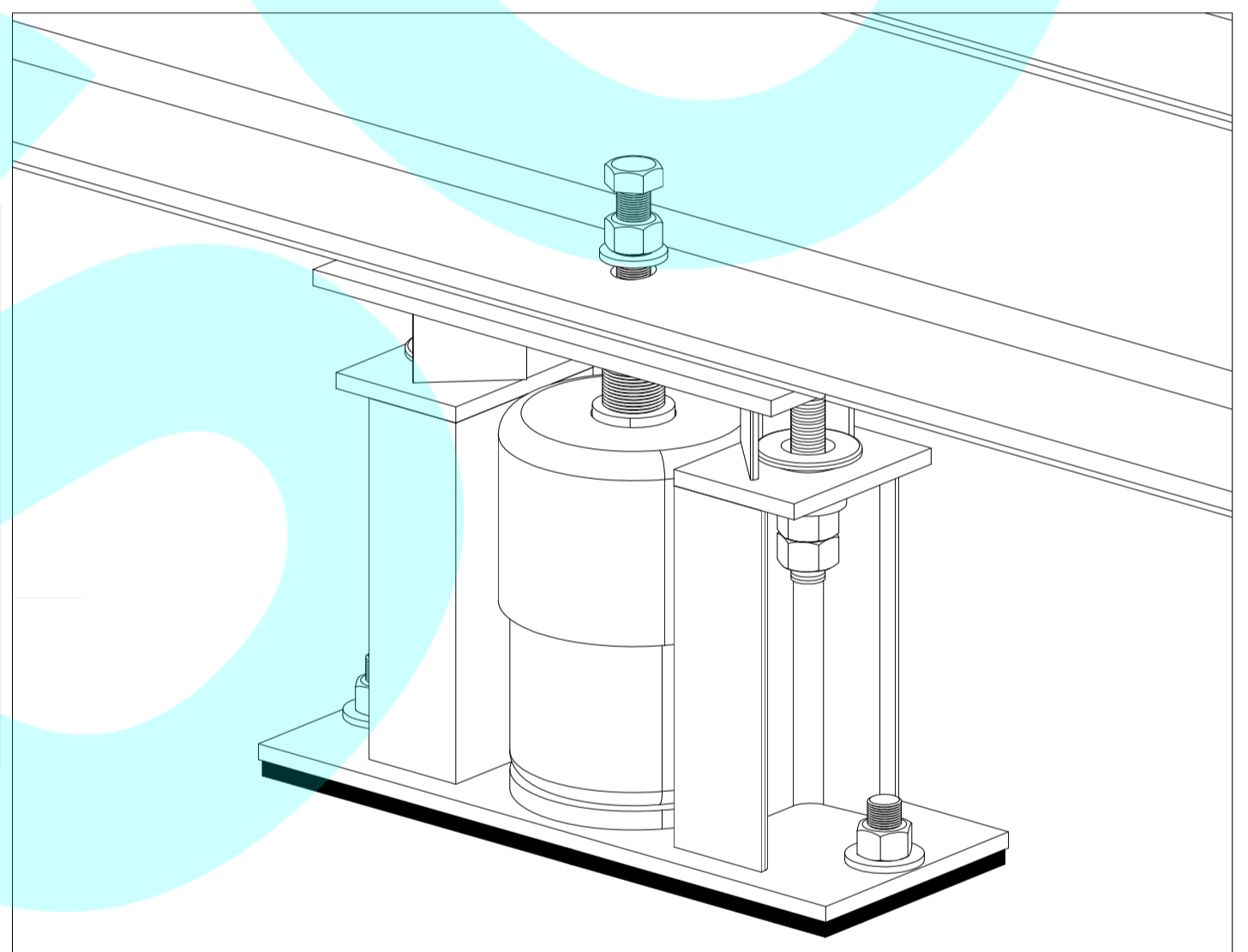

圖4) 使用32mm板手以逆時針方向調整M22螺栓，使彈簧下壓、避震器上蓋鐵上升。

Fig 4) Adjust M22 adjustment bolt in the anti-clockwise direction with 32mm open wrench to press down the spring and to raise the upper iron sheet.

圖5) 調整至避震器上蓋鐵升高，壓墊可以取出時即可完成調整並取出木台。

Fig 5) Adjust until the iron sheet of the isolator arises. Adjustment can be stopped and wooden panel can be removed once you can take out the pressure pad.

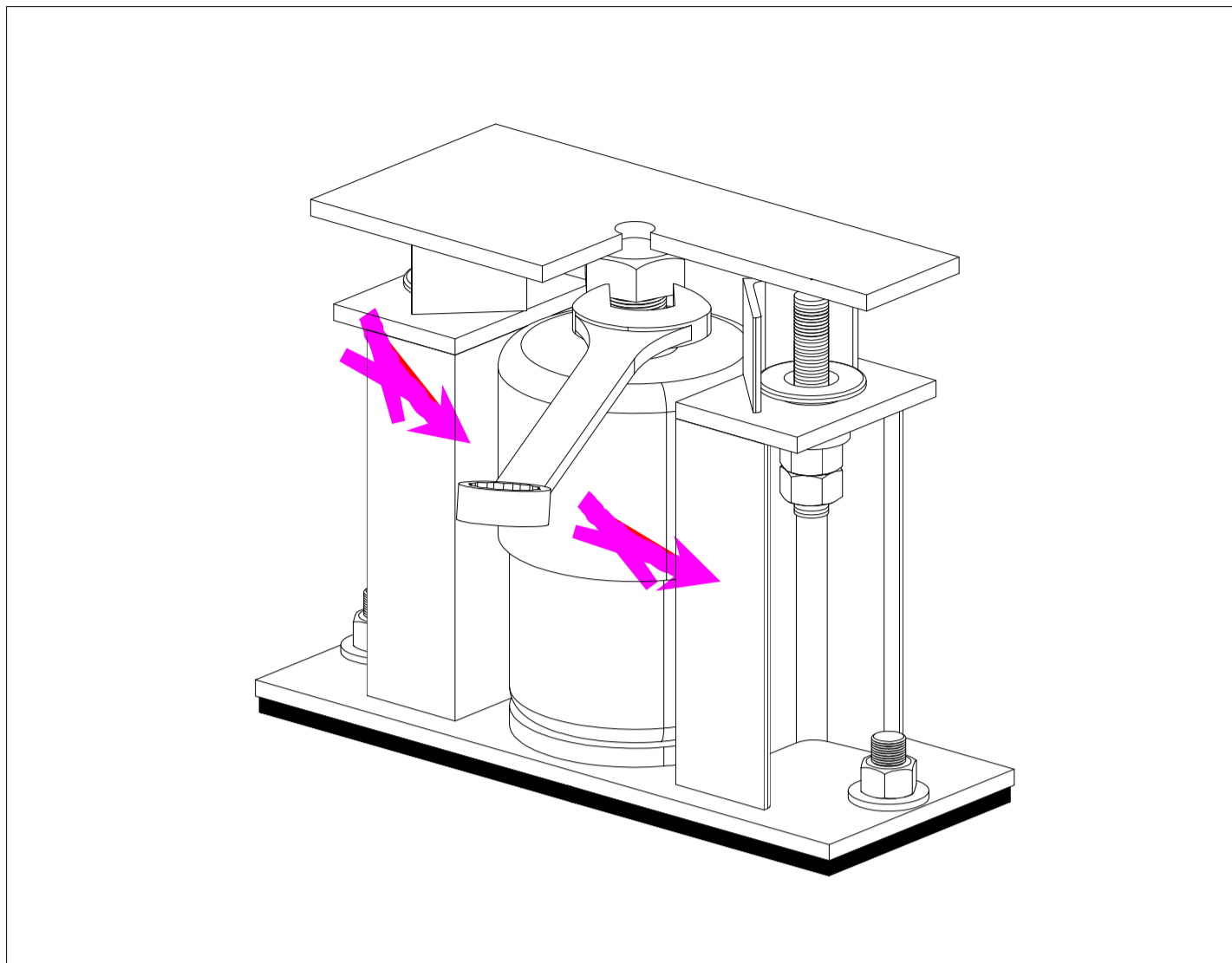
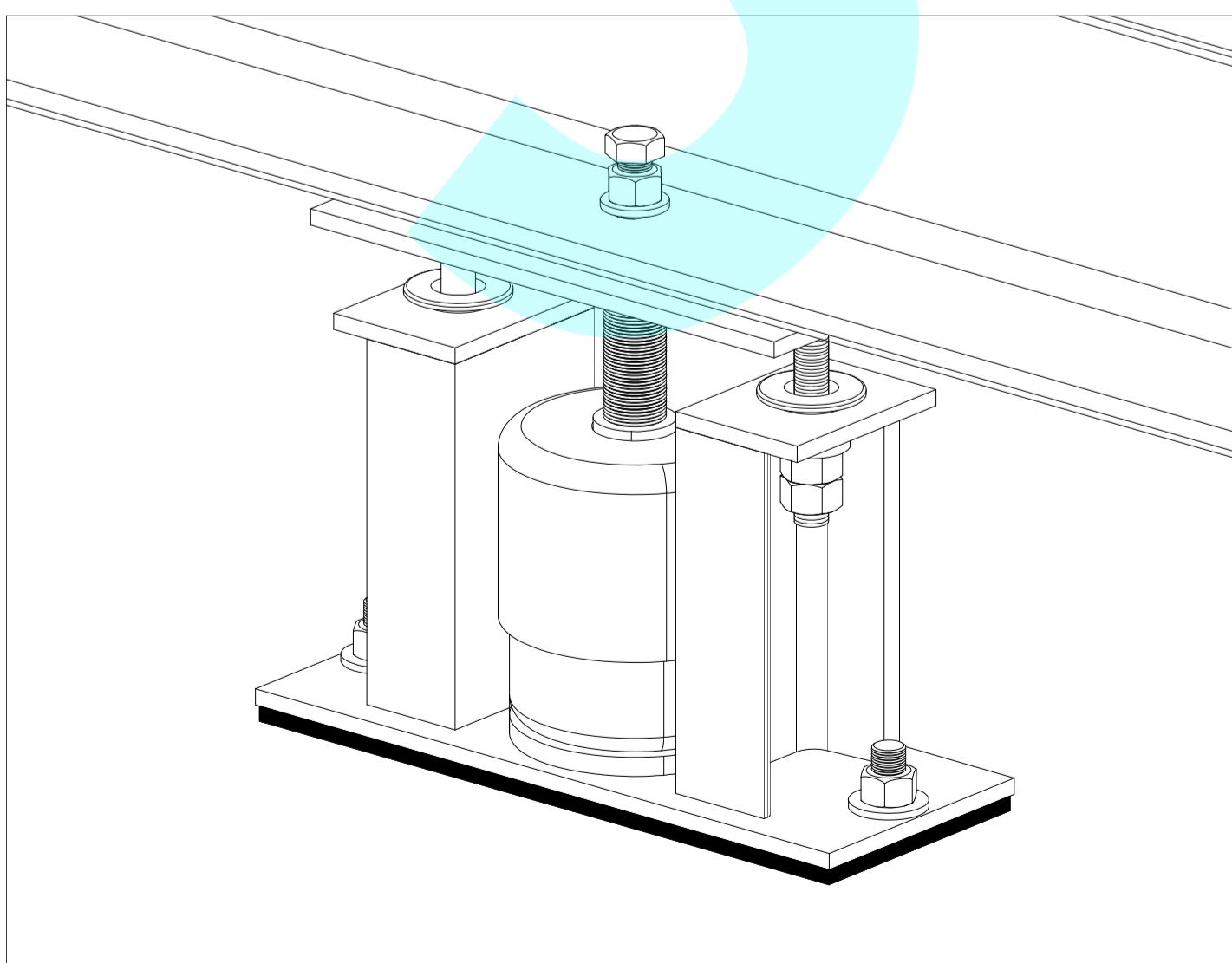
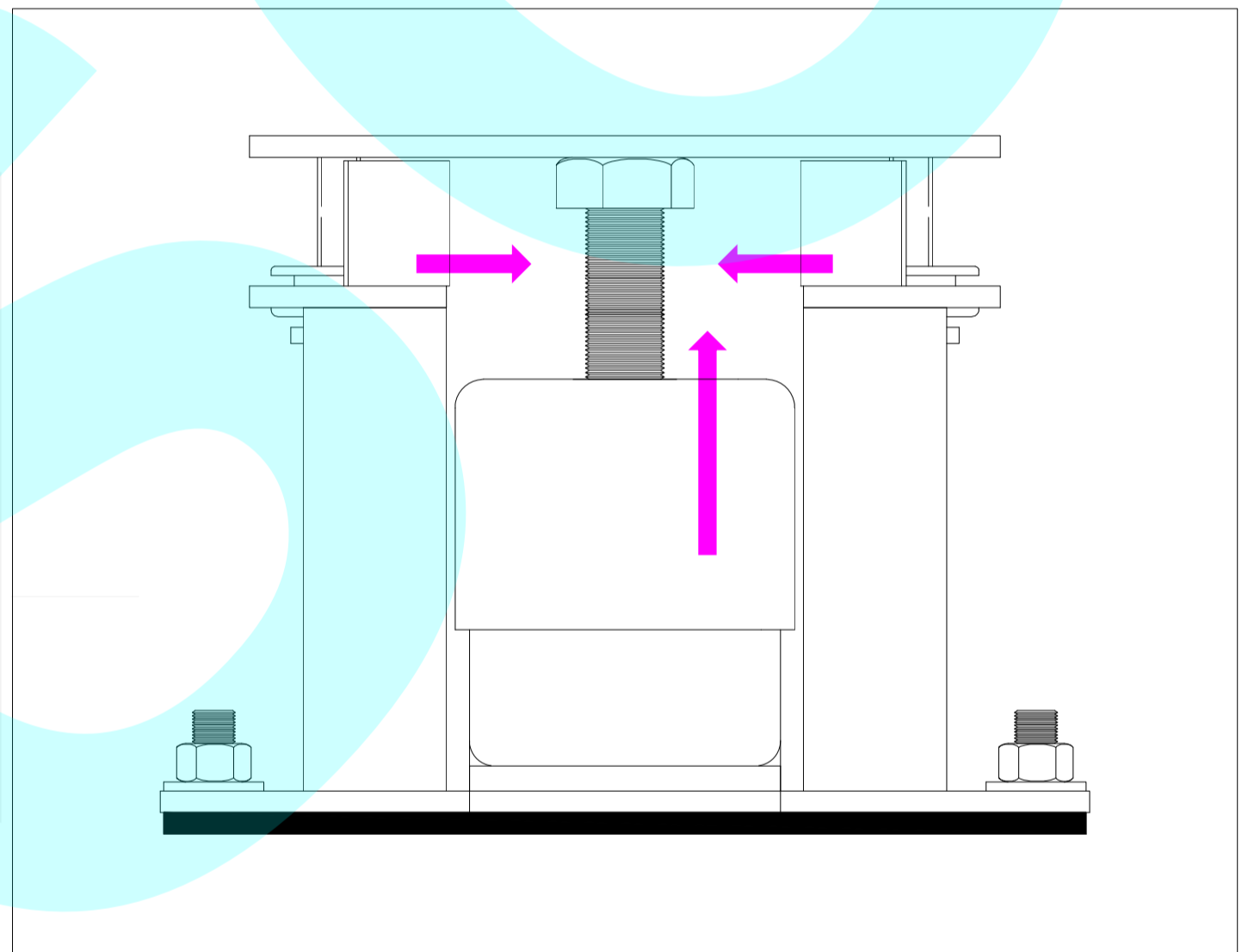

圖6) 將M12螺栓與設備完全鎖緊後，即完成避震器安裝調整。

Fig 6) After the adjustment, lock the isolator with M12 fixed bolt 5-10mm.