

SWB 掣震鋼索安裝說明

SWB Seismic snubber steel rope installation guide

安裝前，請確認避震器之型號規格是否正確。

Before installation, make sure the model and the specification are correct.

安裝說明

Installation guide

- 所需工具：公制口徑19mm (M12)、24mm (M16)、扭力扳手、電熱槍、鋼索剪。

Required tools: 19mm(M12) and 24mm(M16) torque wrenches, electric heat gun, and steel rope cutter.

- 請先於設備端預留掣震彎板安裝之孔位，並以固定螺栓將掣震彎板與設備固定，但不鎖緊。(如圖1)

Reserve the installation holes of seismic snubber bending plate on the equipment and fasten with fixed bolt without locking it (Fig 1).

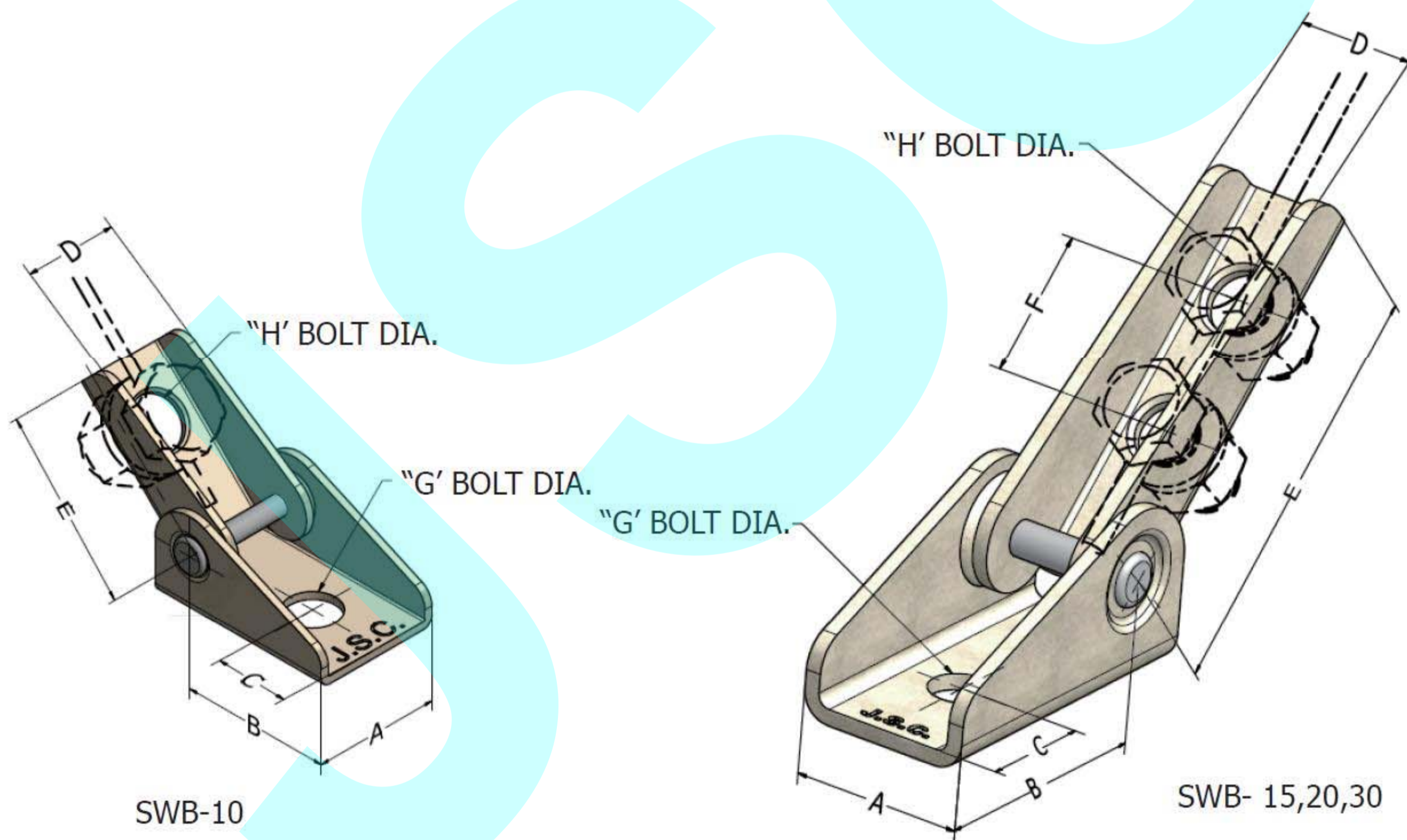

型號 Type	尺寸 Dimension (mm)								鋼索直徑 Steel rope diameter	最大受力 Max force
	A	B	C	D	E	F	G	H	inch	Kgs
SWB-10	32	38	19	23.5	42	無	13	13	1/8"	300
SWB-15	35	50	25	25	80	32	13	13	5/32"	650
SWB-20	50	75	35	34	115	40	18	18	3/16"	1200
SWB-30	50	75	35	34	115	40	18	18	1/4"	2000

安裝說明

Installation guide

- 測量好鋼索從設備端至另一端安裝處所需的安裝長度，使用鋼索剪裁切過長之鋼索；將熱收縮模移至鋼索裁切處，使用加熱工具加熱收縮膜，使其包覆鋼索末端。(如圖2)



Measure the length from the equipment to the installation location. Cut the redundant length with steel rope cutter. Place the heat shrinkable film on the steel rope to wrap the end of the rope (Fig 2).

- 鋼索長度約為鋼索確實拉緊之後再多留約10mm~12mm的長度，不可過份拉緊或鬆弛。

There should be 10mm~12mm length of steel rope left after tightening it.

- 確認鋼索安裝長度後，利用開口扳手鎖固穿孔螺栓組，並使用扭力扳手檢查其鎖固扭力值是否合乎規定值。(如圖3)

Lock the arbitrary bolts with the open wrench after checking the length of the steel rope and make sure the lock torsion comply with the standard (Fig 3).

- 將掣震彎板調整至安裝所需角度後，與基礎螺栓確實鎖緊。(如圖4)

After adjusting the seismic snubber bending plate to the required angle, lock it with the foundation bolt (Fig 4).

- 將設備端所有需安裝的掣震鋼索依序安裝完成。(如圖5)

Install the required seismic snubber steel rope in order (Fig 5).

- 安裝掣震彎板時的X軸及Y軸向角度均建議為45度，實際安裝角度須視施工現場空間而定。(如圖6)

Suggested angle for X and Y axles is 45 degree. The actual installation angle depends on the site (Fig 6).

- 安裝時，請注意安全。

Be cautious during the installation.

※保養點檢項目：定期觀察鎖固螺栓保持鎖固無脫離、保持掣震彎板&鋼索安裝狀態正常。

Maintenance checking points: remain the clamp bolts locked, and the installation status of the seismic snubber bending plate and steel rope normal.

SWB 掣震鋼索圖解說明

SWB Seismic snubber steel rope illustration



圖1) 以固定螺栓將掣震彎板與設備固定，但不鎖緊。

Fig 1) Fasten the seismic snubber bending plate and the equipment with fixed bolt without locking them.

圖2) 調整所需的鋼索長度後將另一端過長之鋼鎖裁切掉後，利用熱收縮膜將鋼索末端包覆。

Fig 2) Cut the redundant length of steel rope with steel rope cutter and wrap it with heat shrinkable film.

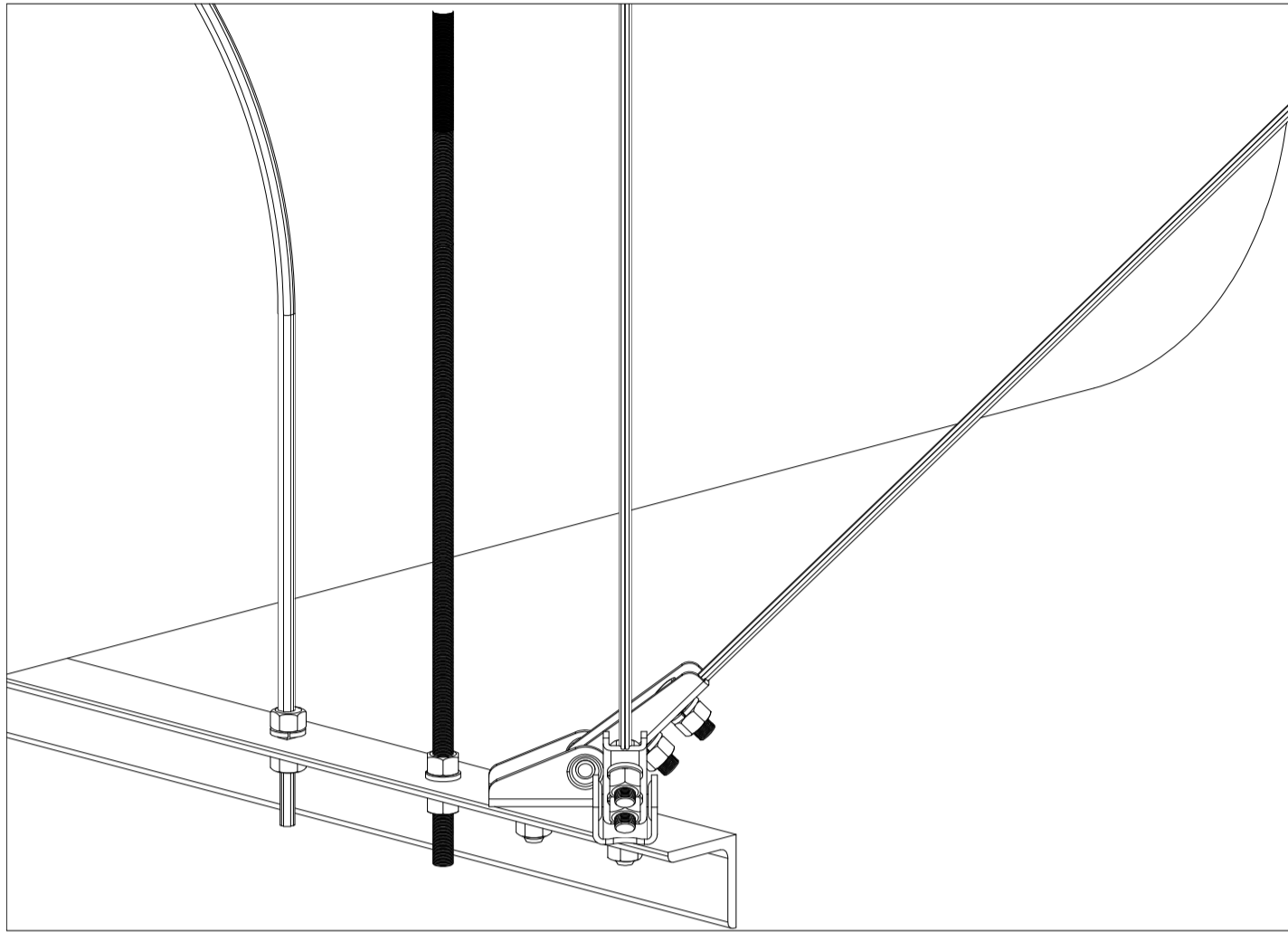

圖3) 以扳手完全鎖固穿孔螺栓，並使用扭力扳手檢查其鎖固扭力值。

Fig 3) Lock the arbitrary bolts with the open wrench and check the lock torsion with torque wrench.

SWB 掣震鋼索圖解說明

SWB Seismic snubber steel rope illustration

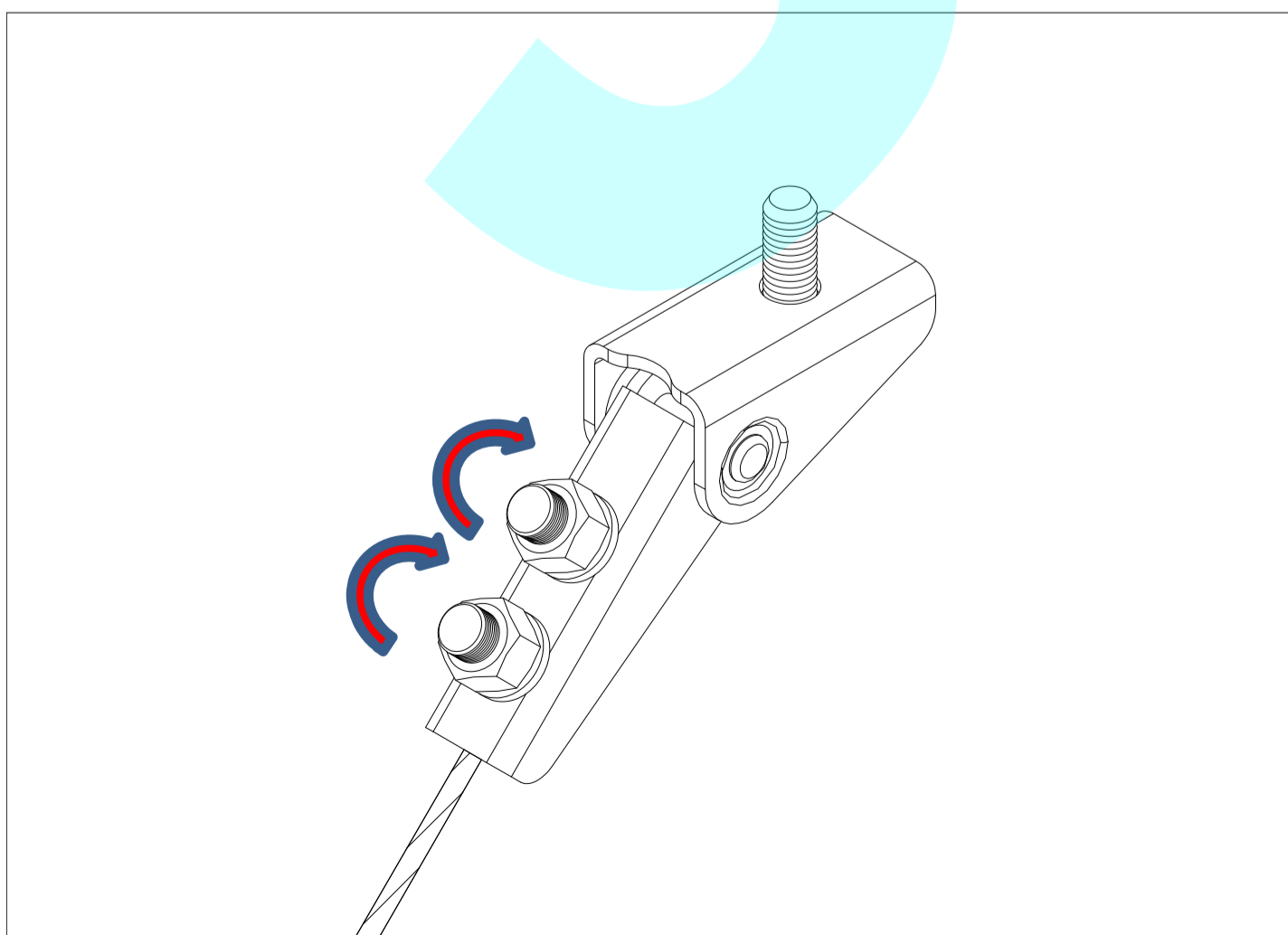
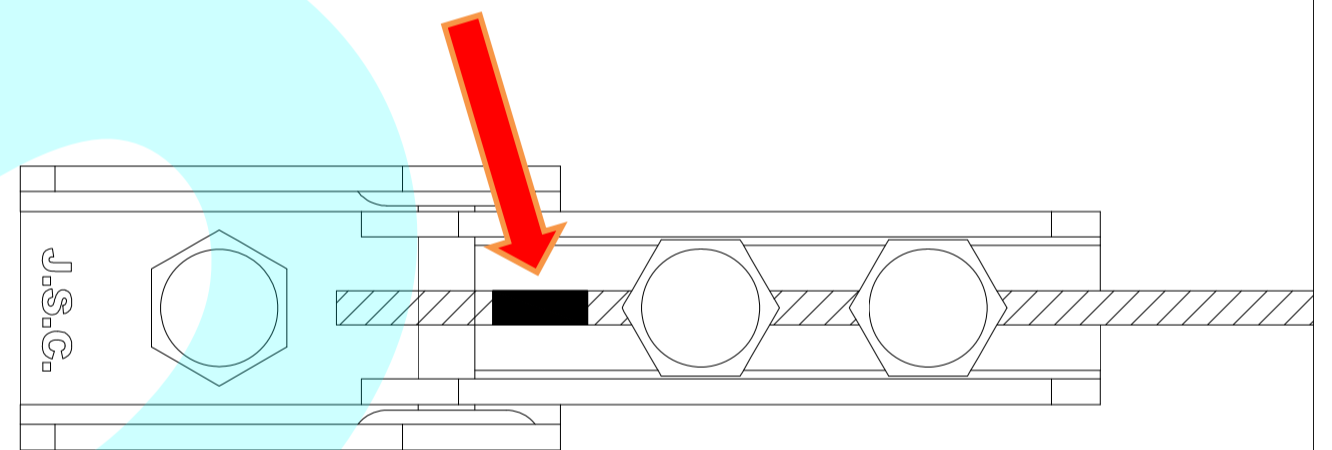

圖4) 調整至所需的安裝角度，將另一端彎板鎖固在安裝位置的基礎螺栓。

Fig 4) After adjusting to the required angle, lock another bending plate with the foundation bolt.

圖5) 確認安裝角度後鎖固設備端的掣震彎板，並檢視各螺栓是否完全鎖固。

Fig 5) Make sure all the bolts on the seismic snubber bending plate are locked.

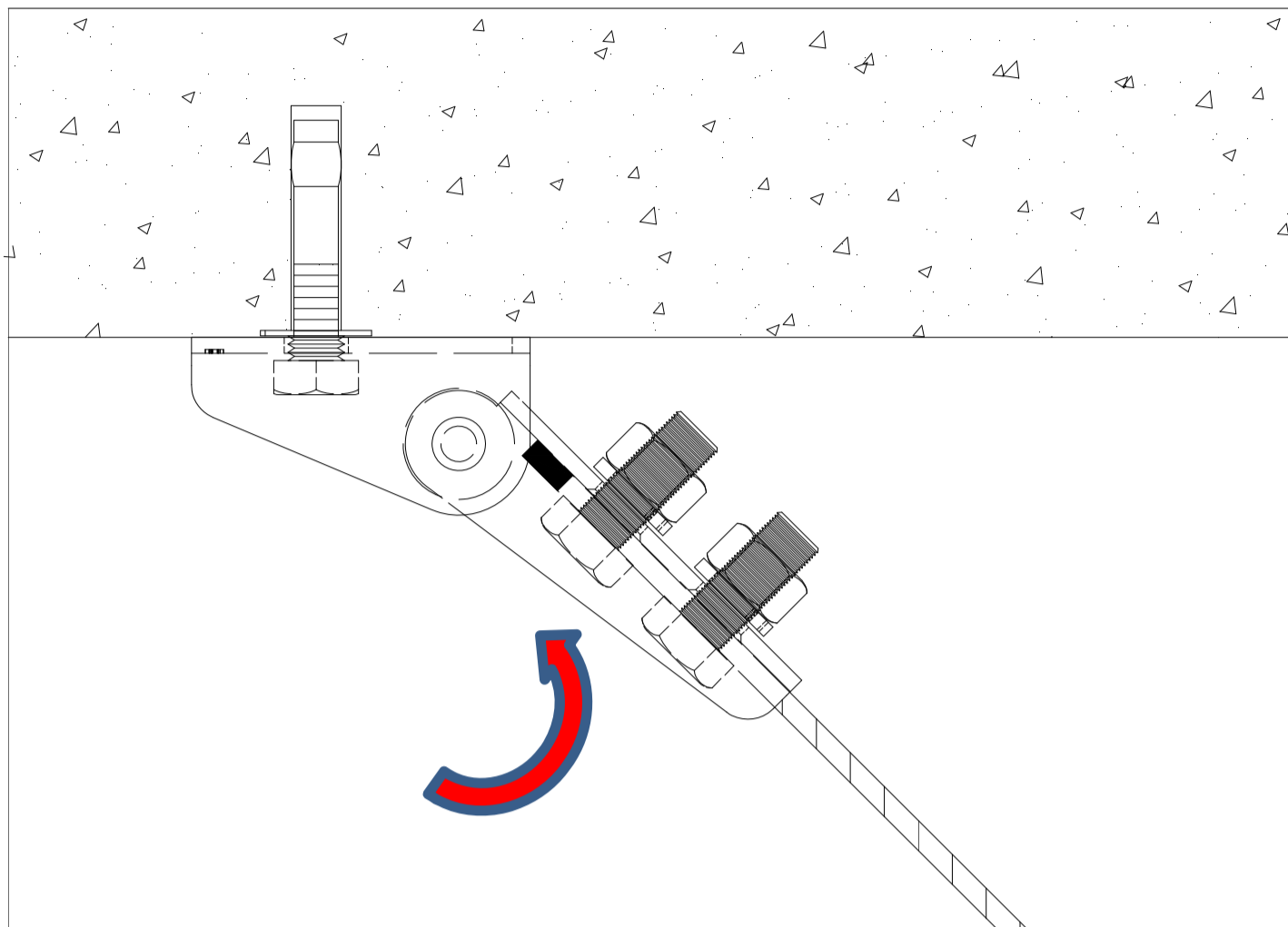

圖6) 安裝時須注意安裝角度，是否合乎規範及現場工地狀況。

Fig 6) Pay attention to whether the installation angle complies with the regulations and sites.

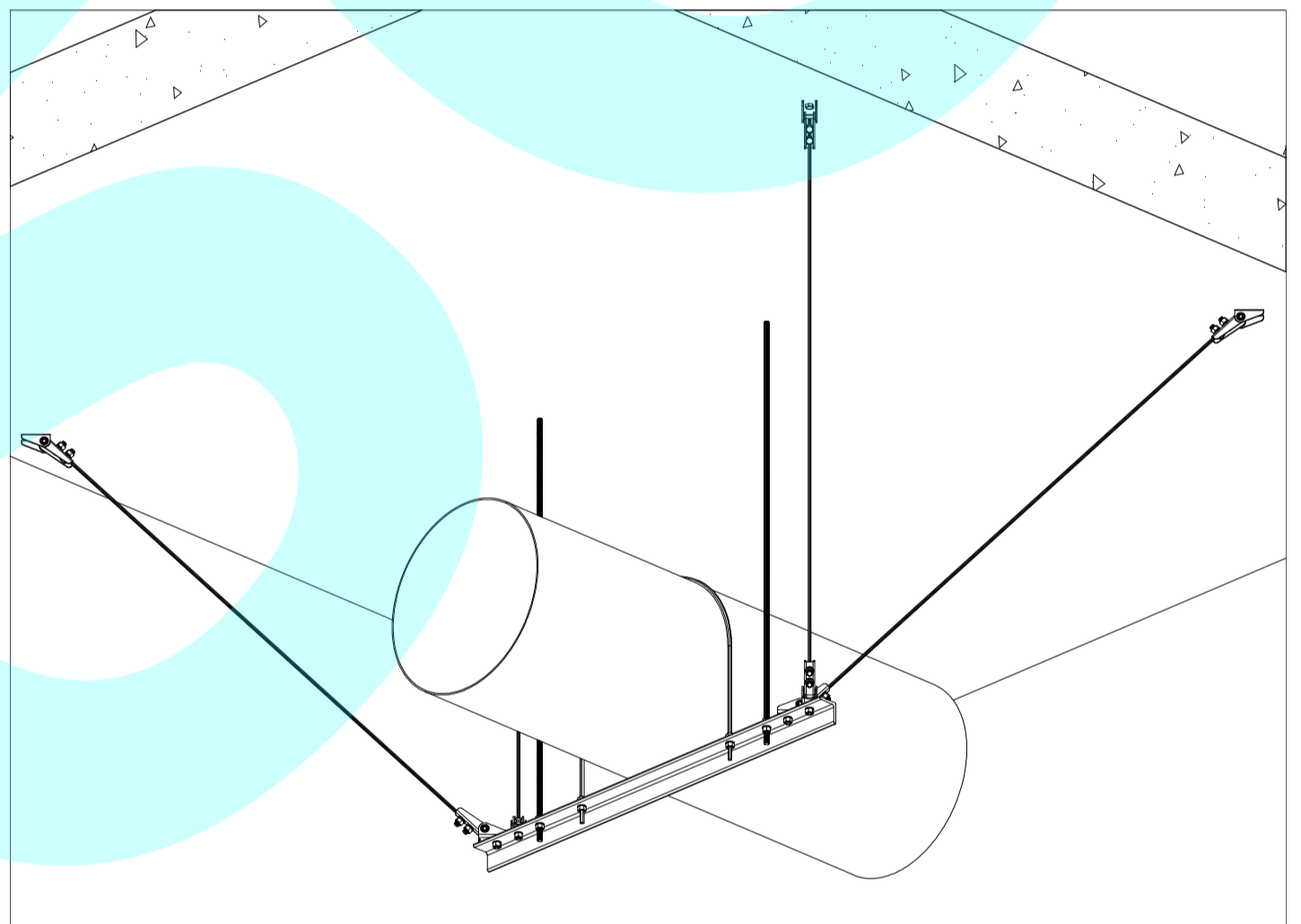