

JSC-SK 氣墊式避震器安裝說明

JSC-SK air mounts installation guide

安裝前，請確認避震器之型號規格是否正確。

Before installation, make sure the model and the specification are correct.

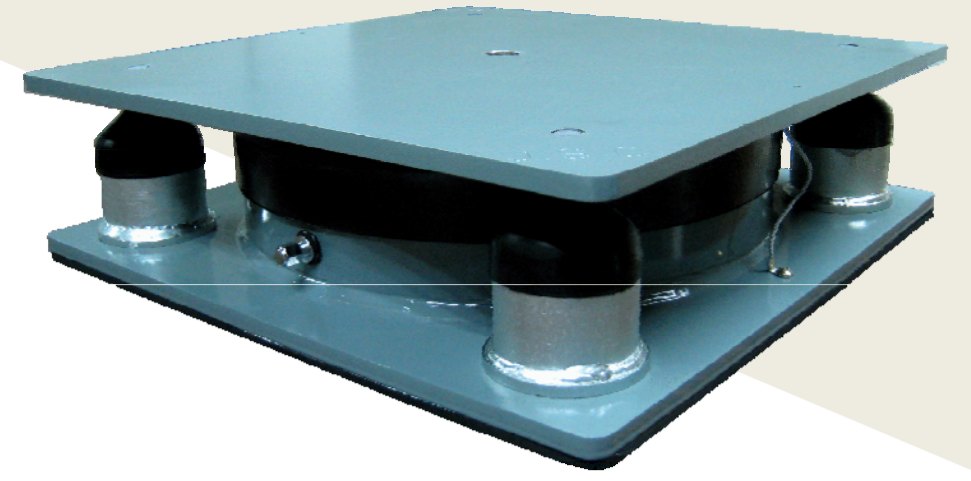

安裝說明

Installation guide

- 所需工具：24mm開口扳手(M16)、36mm開口扳手(M24)、打氣筒、壓力表、爪式千斤頂。(如圖1)

Required tools: 24mm (M16) 、 26mm (M146) open wrench, air pump, pressure gauge, and claw jack (Fig 1).

- 在無荷重狀態時，氣墊式避震器內請勿充氣。

Do not inflate the air mounts without loading.

- 以爪式千斤頂慢慢將設備抬高至臨時木台相同高度。(如圖2)

Elevate the equipment to the same height as the wooden panel with claw jack gradually (Fig 2).

型號 Type	尺寸 Dimension			荷重 Load (Kgs)		固定螺栓 Fixed bolt CS*L
	A	B	H	Min	Max	
JSC-1200-SK	300	300	120	900	1200	M16-110L
JSC-1600-SK	350	350		1200	1600	M16-110L
JSC-2000-SK	380	380		1600	2000	M16-110L
JSC-3500-SK	500	500		2800	3500	M20-150L
JSC-6000-SK	575	575		3500	6000	M24-150L
JSC-9000-SK	670	670		6000	9000	M24-150L

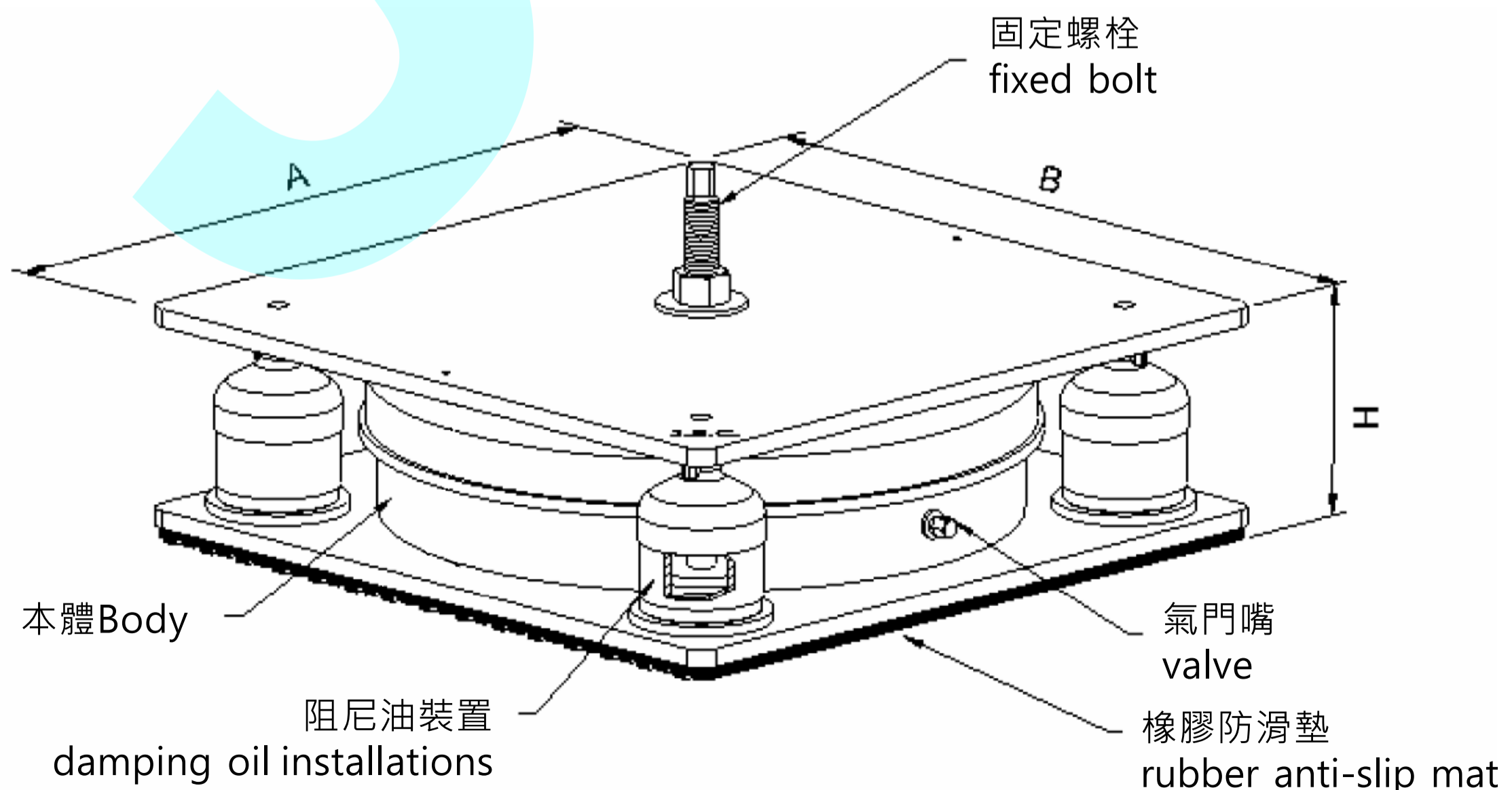

JSC-SK 氣墊式避震器安裝說明

JSC-SK air mounts installation guide

安裝說明

Installation guide



- 將臨時木台(115~120 mm)放入設備底部。(如圖3)

Place the wooden panel (115~120mm) at the bottom of the equipment (Fig 3).

- 依序將避震器置入設備安裝位置，並以螺栓固定之。(如圖4)

Install the mounts on the equipment in order and lock them (Fig 4).

- 充氣時，以空壓機或腳踏式充氣筒即可充氣，注意充氣時避震器高度不可超出120mm，避震器內壓過高時；按下氣門嘴即可放氣，充氣完成後將臨時木台取出。(如圖5)

Inflate with compressor or pedal pump. When the pressure is too high inside the mounts, press the valve to deflate. Take out the wooden panel after inflation (Fig 5).

- 氣門嘴為CNS TV-8標準螺紋。

The Valve applies standard CNS TV-8 thread.

- 最大使用內壓為 $4.5\text{kg/cm}^2 = 0.44\text{Mpa}$ ，但充氣時以避震器高度為調整基準。(高度為115mm~120mm)

Maximum inner pressure is $4.5\text{kg/cm}^2 = 0.44\text{Mpa}$. Apply the height of the mounts (110mm~120mm) as the adjustment standard while inflating.

- 以水平尺檢查設備的水平度，並以充氣及放氣來調整水平即可。(如圖6)

Check the level with level bar and adjust it with inflation and deflation (Fig 6).

- 使用溫度範圍為 $-10\text{ }^{\circ}\text{C} \sim 60\text{ }^{\circ}\text{C}$ 。

Applied temperature range is between $-10\text{ }^{\circ}\text{C} \sim 60\text{ }^{\circ}\text{C}$.

- 安裝及使用時，請注意勿傷及氣門嘴及氣墊本體橡膠。

Do not damage the valve and the air cushion rubber during the installation and the application.

※保養點檢項目：每月觀察避震器高度是否正常、適時充氣維持氣墊內壓；保持避震器安裝狀態正常。

Maintenance checking points: check the height of the mounts, remain the inner pressure inside the air cushion by necessary inflation, and maintain the installation of the mounts monthly.

※移動設備前，請先按下氣門嘴將氣墊放氣；以免造成氣墊損壞。

Deflate the air through the valve to avoid the damage before moving the equipment.

JSC-SK 氣墊式避震器圖解說明

JSC-SK Air mounts illustration



圖1)需要工具：爪式千斤頂、水平尺、扳手、壓力錶、打氣筒。
Fig 1) Required tools: claw jack, level bar, open wrench, pressure gauge, and air pump.

圖2)使用爪式千斤頂緩慢將設備頂起。
Fig 2) Elevate the equipment with claw jack gradually.



圖3)放置臨時木台110~120mm高度。
Fig 3) Place the wooden panel to 110~120mm.

JSC-SK 氣墊式避震器圖解說明 JSC-SK Air mounts illustration



圖4)將避震器置入安裝處，並以螺栓固定之。
Fig 4) Install the mounts on the equipment in order and lock them.

圖5)使用打氣筒打氣至避震器，最大使用內壓為 $4.5\text{kg}/\text{cm}^2 = 0.44\text{Mpa}$ ；最大荷重時標準高度為 120mm 此時充氣完成後，即可取出臨時木台。

Fig 5) Inflate with air pump. Maximum inner pressure is $4.5\text{kg}/\text{cm}^2 = 0.44\text{Mpa}$ and the height of maximum loading is 120mm . Take out wooden panel after inflation.



圖6)利用水平尺檢視設備水平。
Fig 6) Check the level with level bar.