

MS 型彈簧式避震器安裝說明

MS spring isolator installation guide

安裝前，請確認避震器之型號規格是否正確。

Before installation, make sure the model and the specification are correct.

安裝說明

Installation guide

- 所需工具：公制口徑開口扳手 10mm (M6)。

Required tools: open wrench.

- 檢查附件是否齊全，避震器有無缺陷破損。(如圖1)

Check the isolator and other accessories see if they are all completely or having any defects (Fig 1).

- 將避震器放置於與設備的正確安裝位置。(如圖2)

Place the isolator on the correct installation position (Fig 2).

- 鎖緊螺栓和墊圈，確保設備和避震器固定。(如圖3)

Fasten the bolts and washers to ensure the equipment feet holes are fixed to the isolator (Fig 3).

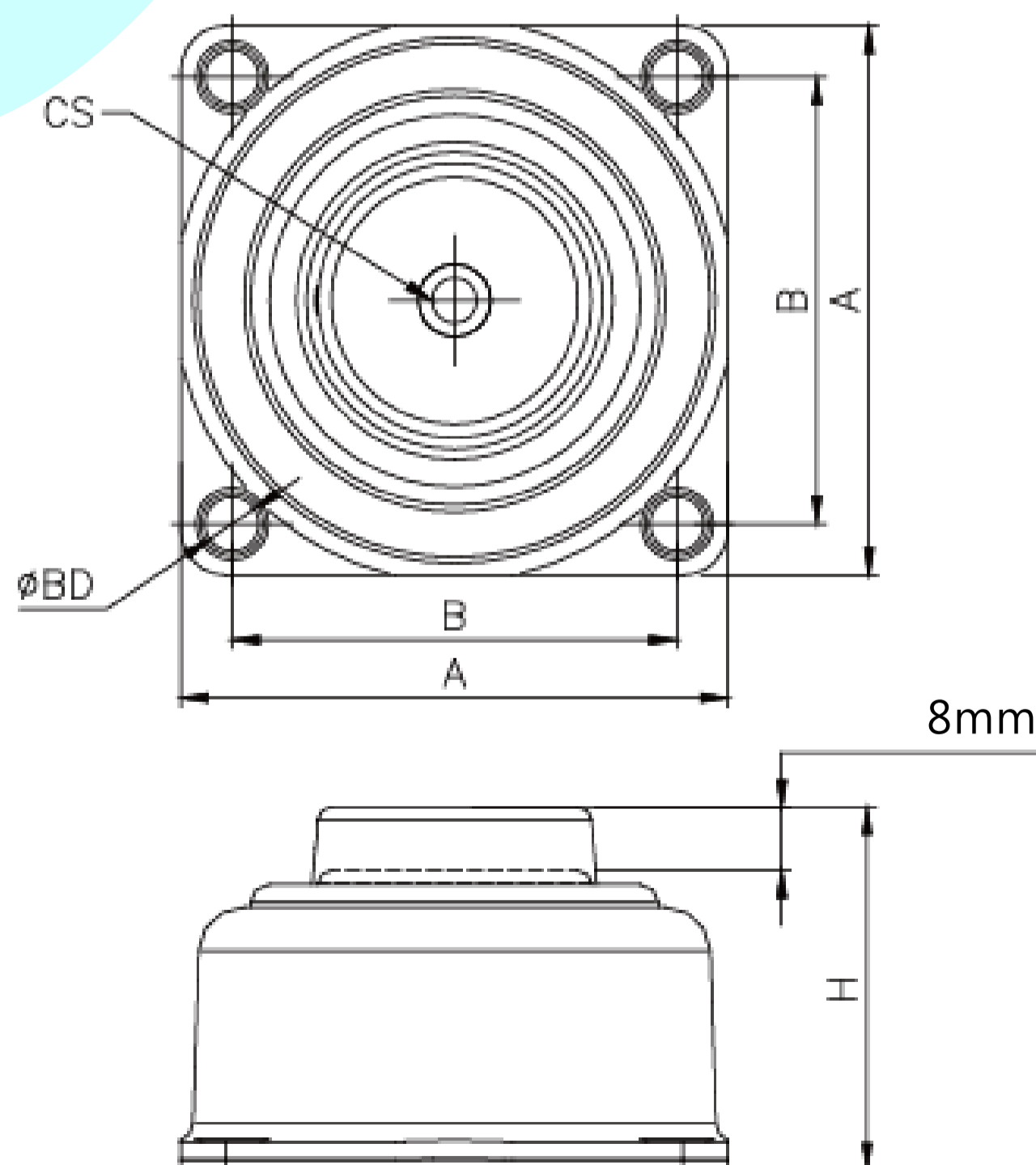
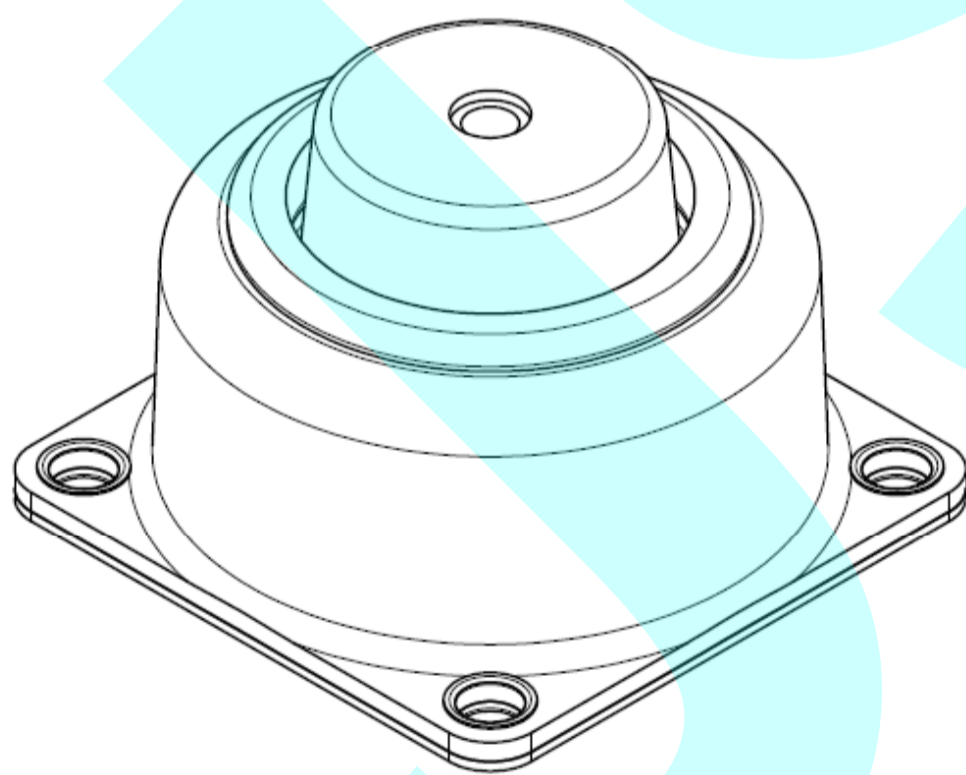

| 型號 Type | 尺寸 Dimension(mm) | | | | | 荷重 Load |
|------------|------------------|----|----|-----|----|---------|
| | A | B | H | BD | CS | Kgs |
| MS-005 | 61 | 49 | 42 | 5.2 | M6 | 4.5~7.5 |
| MS-010 | | | | | | 7~11 |
| MS-015 | | | | | | 10~17.5 |
| MS-025 | | | | | | 17~28 |

MS 型彈簧式避震器圖解說明 MS spring isolator illustration



圖1)檢查附件是否齊全，避震器有無缺陷破損。
Fig 1) Check the isolator and other accessories see if they are all completely or having any defects.

圖2)將避震器放置於與設備的正確安裝位置。
Fig 2) Place the isolator on the correct installation position.

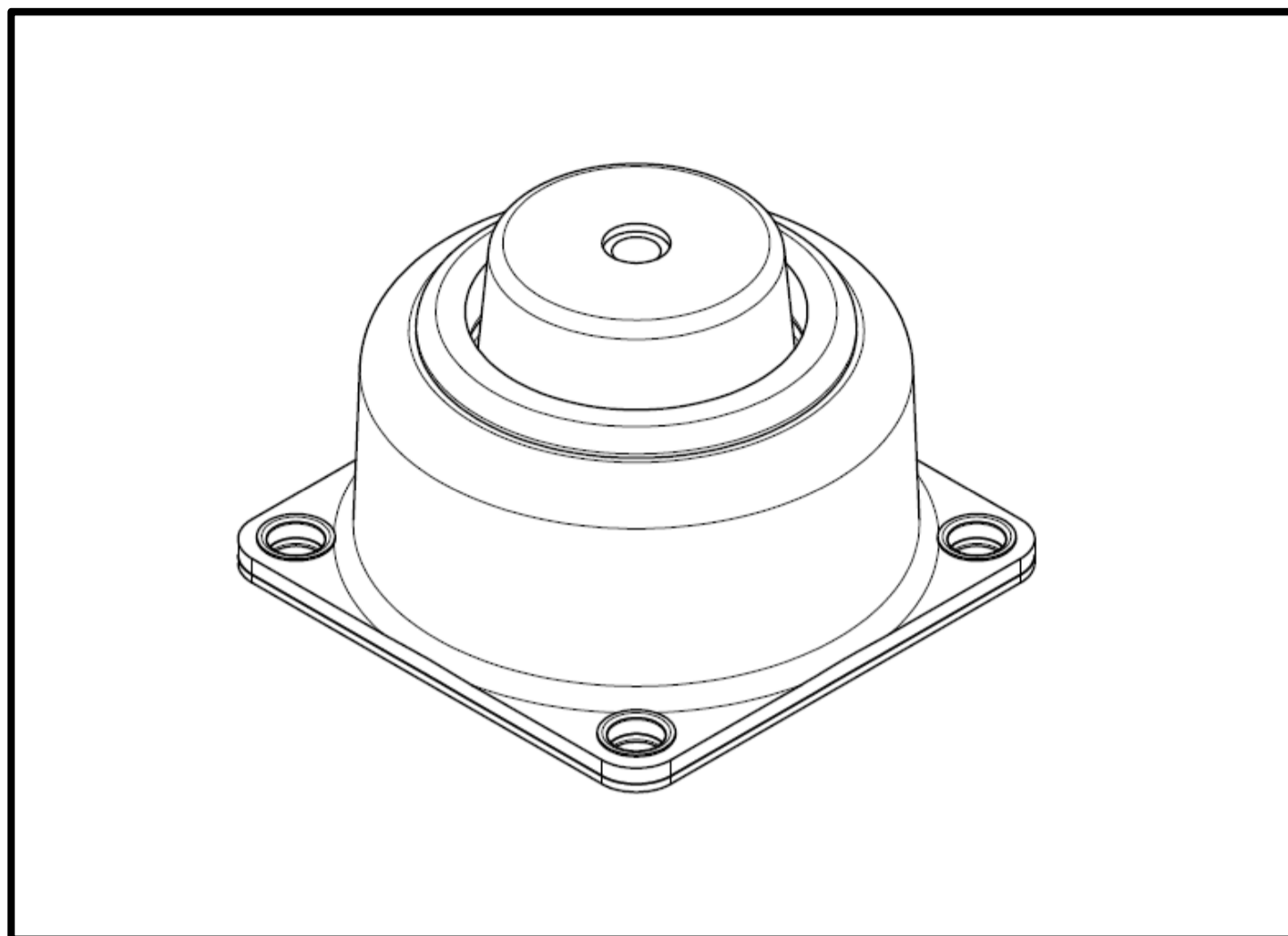
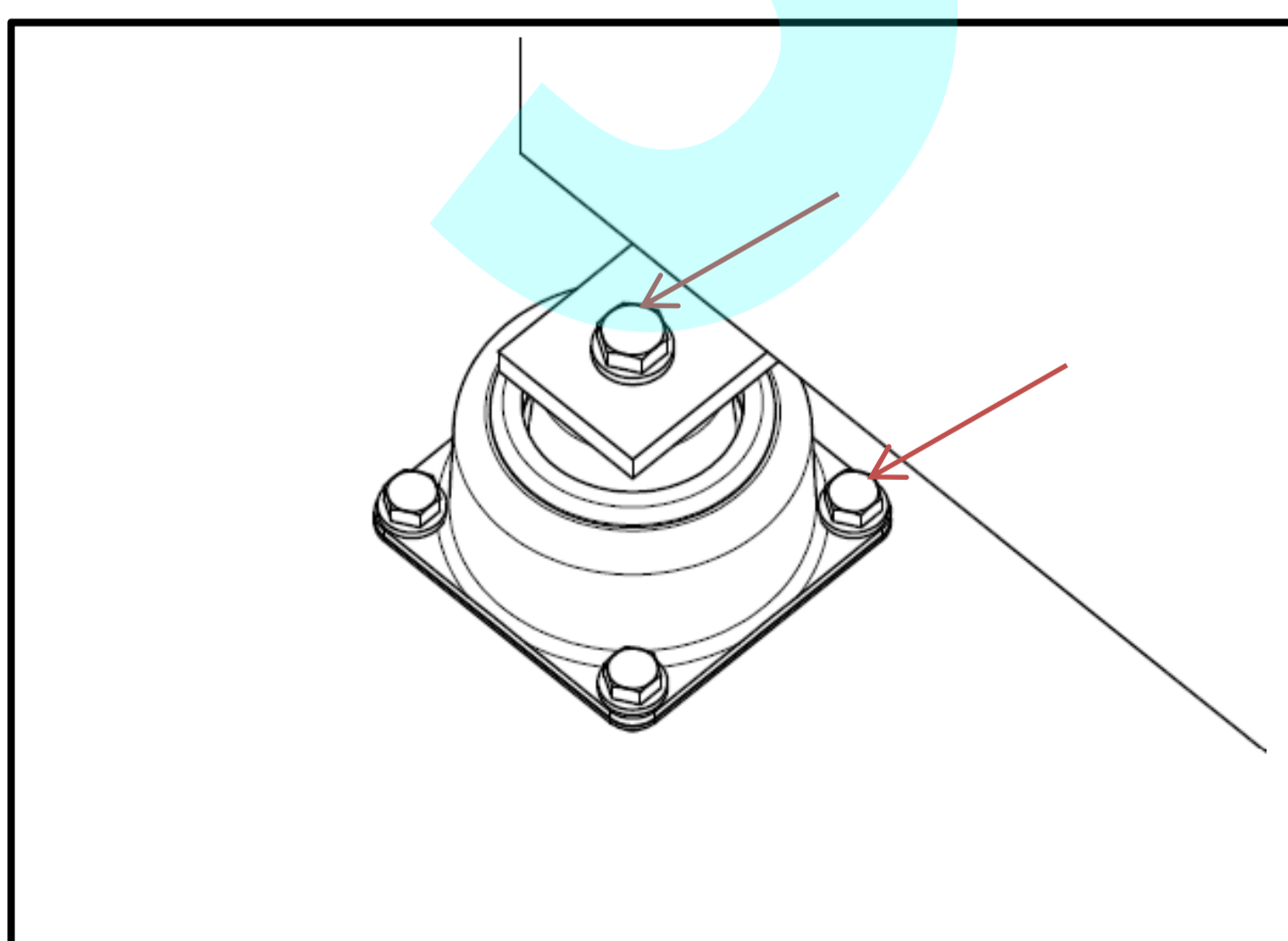
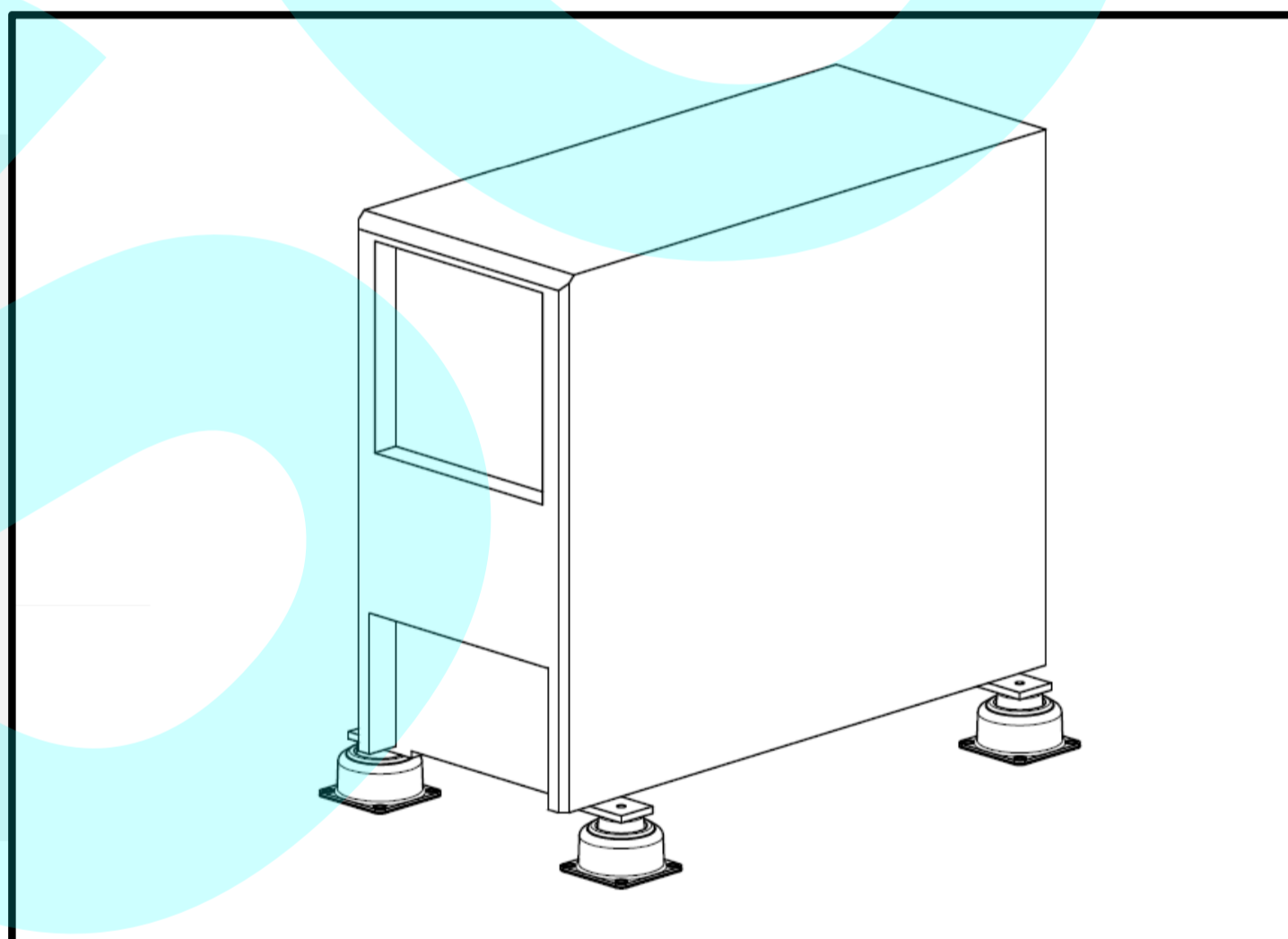

圖3)鎖緊螺栓和墊圈，確保設備和避震器固定。
Fig 3) Fasten the bolts and washers to ensure the equipment feet holes are fixed to the isolator.