

# JL 型彈簧式避震器安裝說明

## JL spring isolator installation guide

安裝前，請確認避震器之型號規格是否正確。

Before installation, make sure the model and the specification are correct.

### 安裝說明

### Installation guide

- 所需工具：公制口徑17mm (M10) 開口扳手、爪式千斤頂。

Required tools: 17mm(M10) open wrench and claw jack.

- 可先行放置與避震器高度相同的臨時木台於設備安裝處，再安裝設備。(如圖1)

Place the wooden panel with the same height as the mounts on the installation before installing (Fig 1).

- 將避震器放置於與設備的正確安裝位置。(如圖2)

Place the mounts on the installation location (Fig 2).

- 使用基礎螺栓將避震器固定於地面基礎上。(如圖3))

Fasten the mounts with foundation bolt on the ground (Fig 3).

- 以M10固定螺栓將避震器與設備固定，略為鎖固。(如圖4)

Fasten the mounts and the equipment with M10 fixed bolt without locking them (Fig 4).

- 使用爪式千斤頂將設備下之臨時木台取出，取出後避震器即會受力下壓。(如圖5)

Apply claw jack to remove the wooden panel beneath the equipment to press down the mounts (Fig 5).

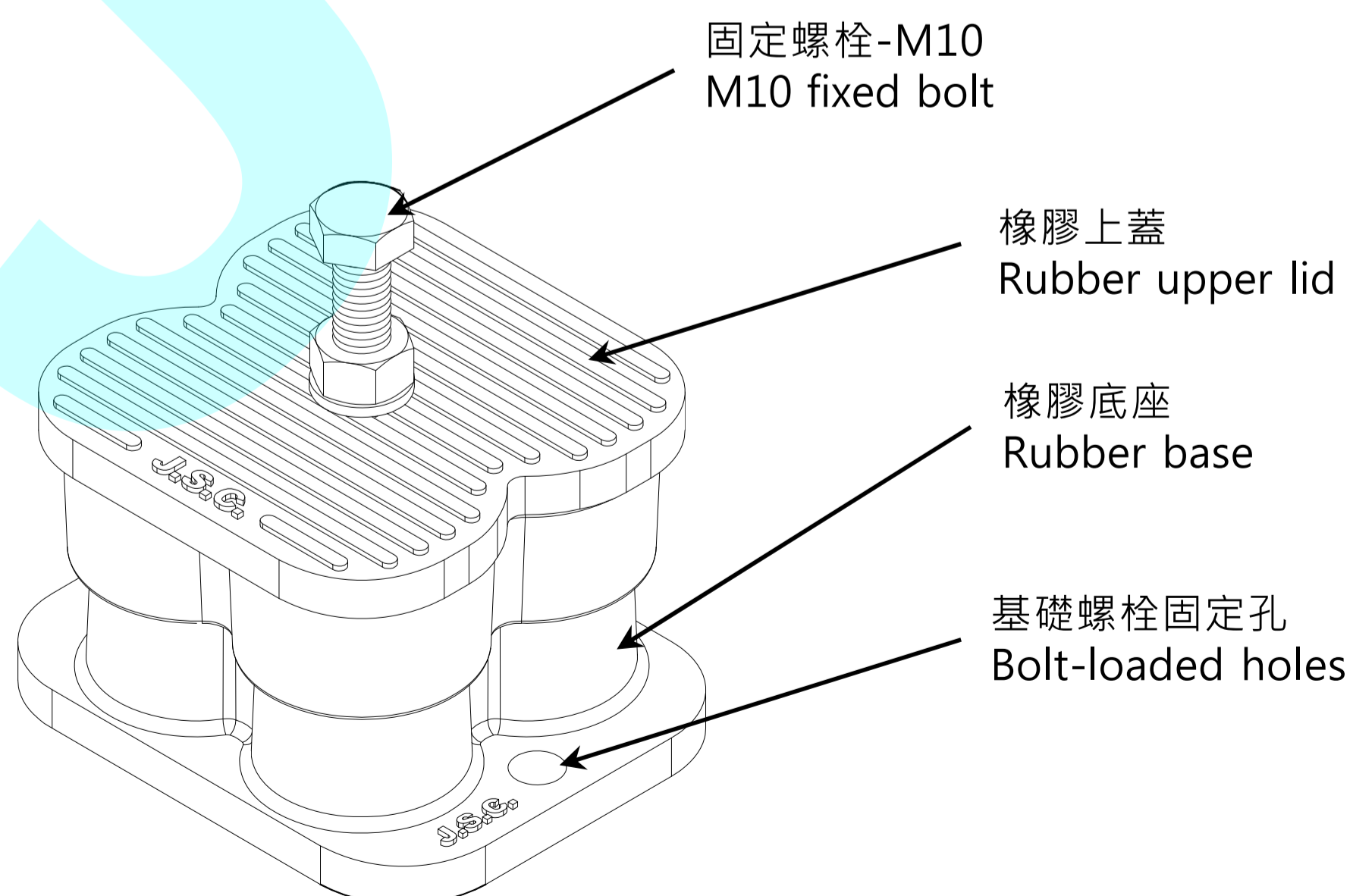

# JL 型彈簧式避震器安裝說明

## JL spring isolator installation guide

### 安裝說明

### Installation guide

- 將M10固定螺栓確實與設備鎖緊，即完成避震器之安裝調整。(如圖6)

After the adjustment, lock the mounts with M10 fixed bolt (Fig 6).

- 安裝後請檢查彈簧之下壓量，安裝完成後之避震器高度若低於50mm，應予更換較大荷重之規格，並請洽本公司業務人員。

Check the press amount of the spring after the installation. If the height of the mounts appears less than 50mm, please replace with bigger loading by contacting our staff.

- 安裝時，請注意安全。

Be cautious during the installation.

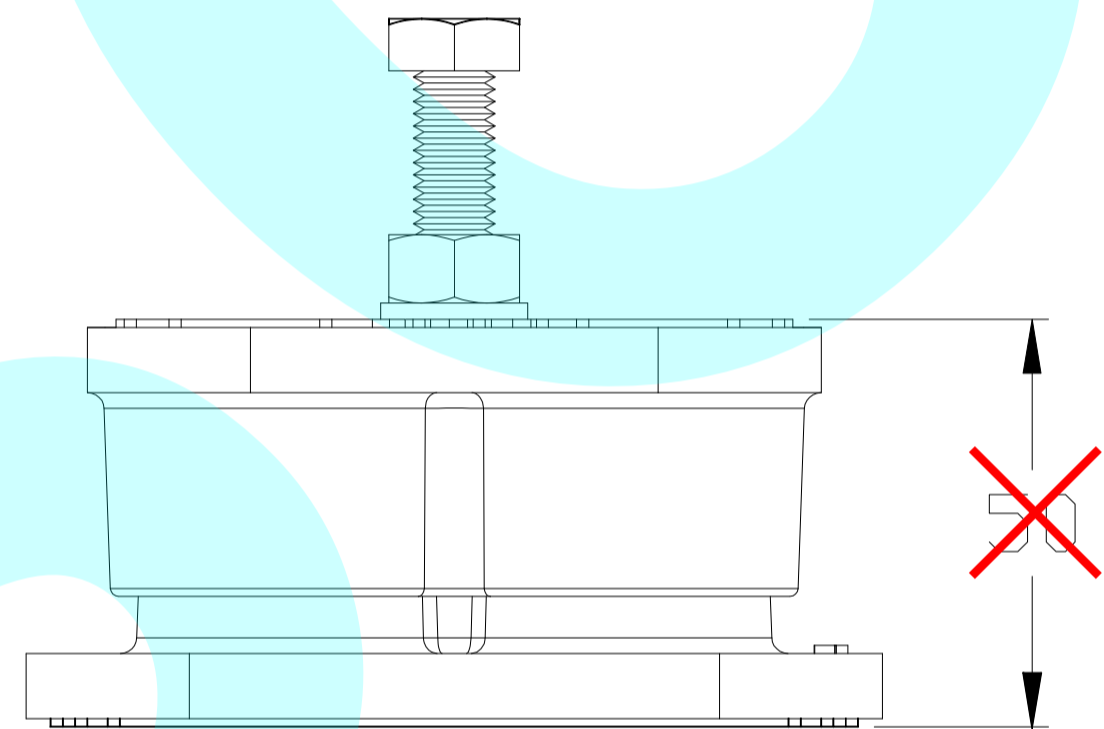

安裝完成後避震器高度若低於50mm為超重現象，請更換型號

If the height of the mounts is less than 50mm after the installation, please replace with another model.

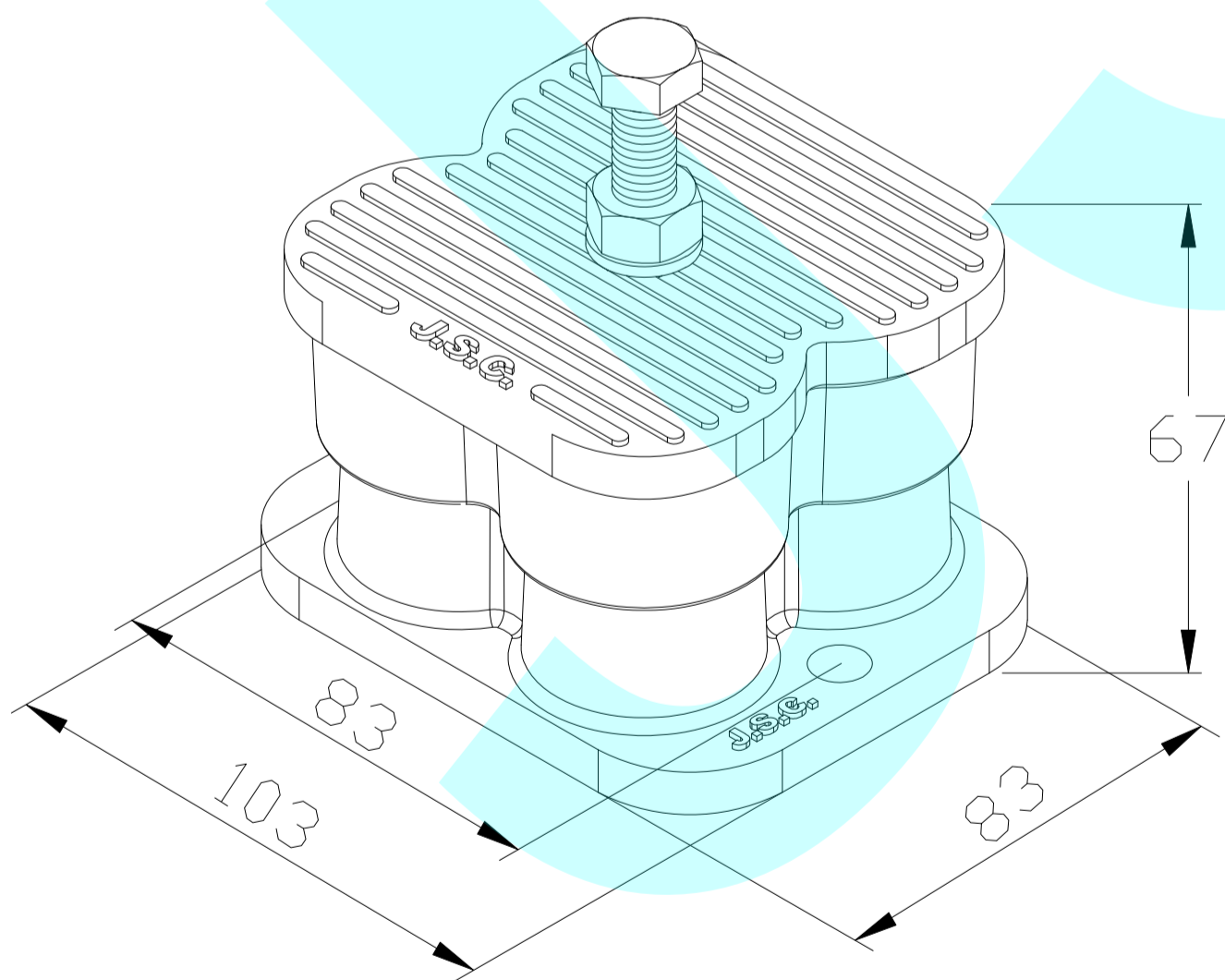

※保養點檢項目：每月觀察固定螺栓&基礎螺栓保持鎖固、保持避震器安裝狀態&彈簧下壓撓度正常。

Maintenance checking points: remain fixed bolt and foundation bolt locked, installation of the mounts, and the deflection of the spring monthly.

## JL 型彈簧式避震器圖解說明 JL spring isolator illustration



圖1)安裝設備時可先放置與避震器相同高度之臨時木台。

Fig 1) Place the wooden panel with the same height as the mounts on the installation before installing.

圖2)將避震器置入設備預定安裝位置處。

Fig 2) Place the mounts on the installation location.

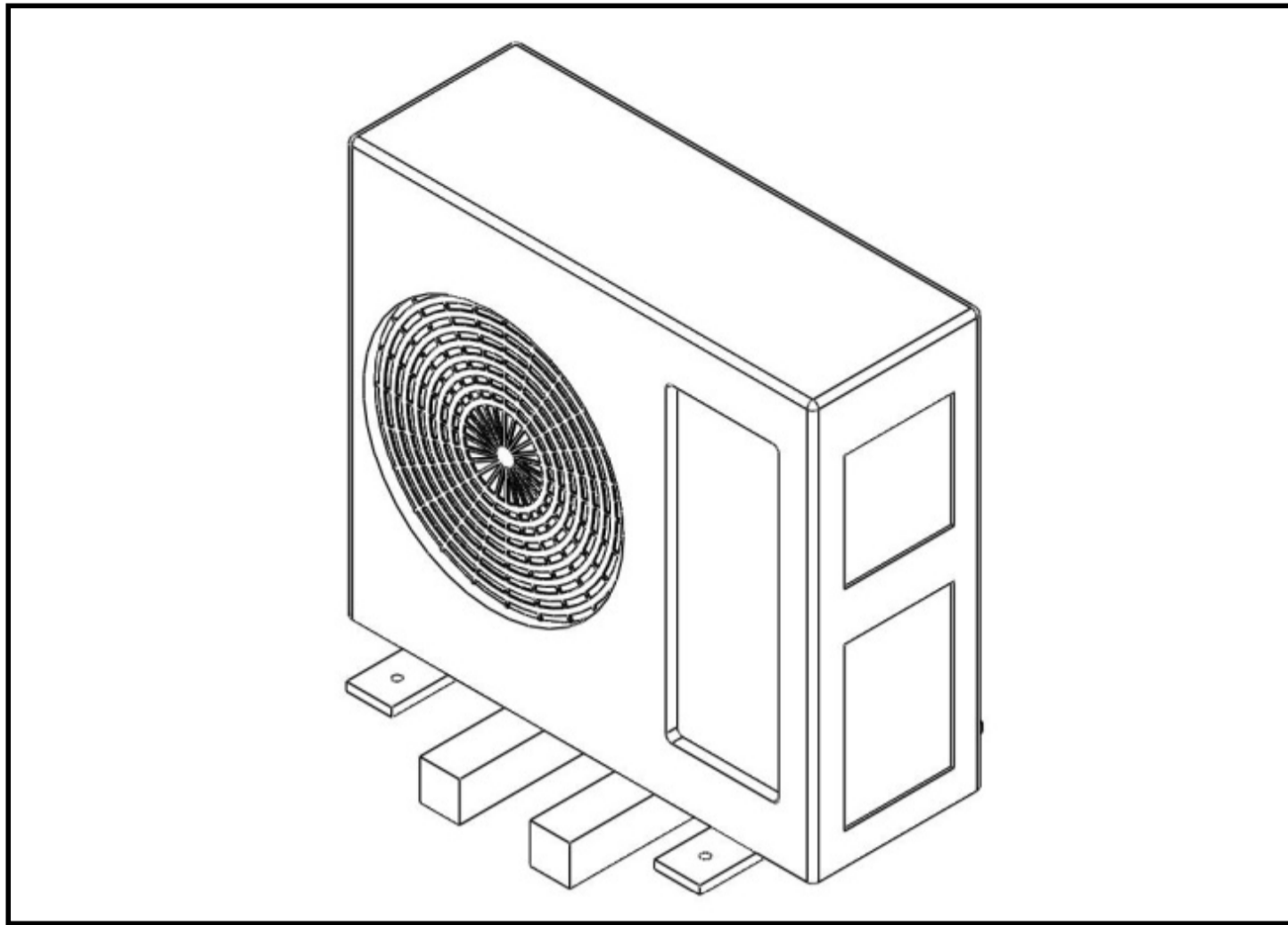

圖3)使用基礎螺栓將避震器固定於地面基礎上。

Fig 3) Fasten the mounts with foundation bolt on the ground.

## JL 型彈簧式避震器圖解說明 JL spring isolator illustration

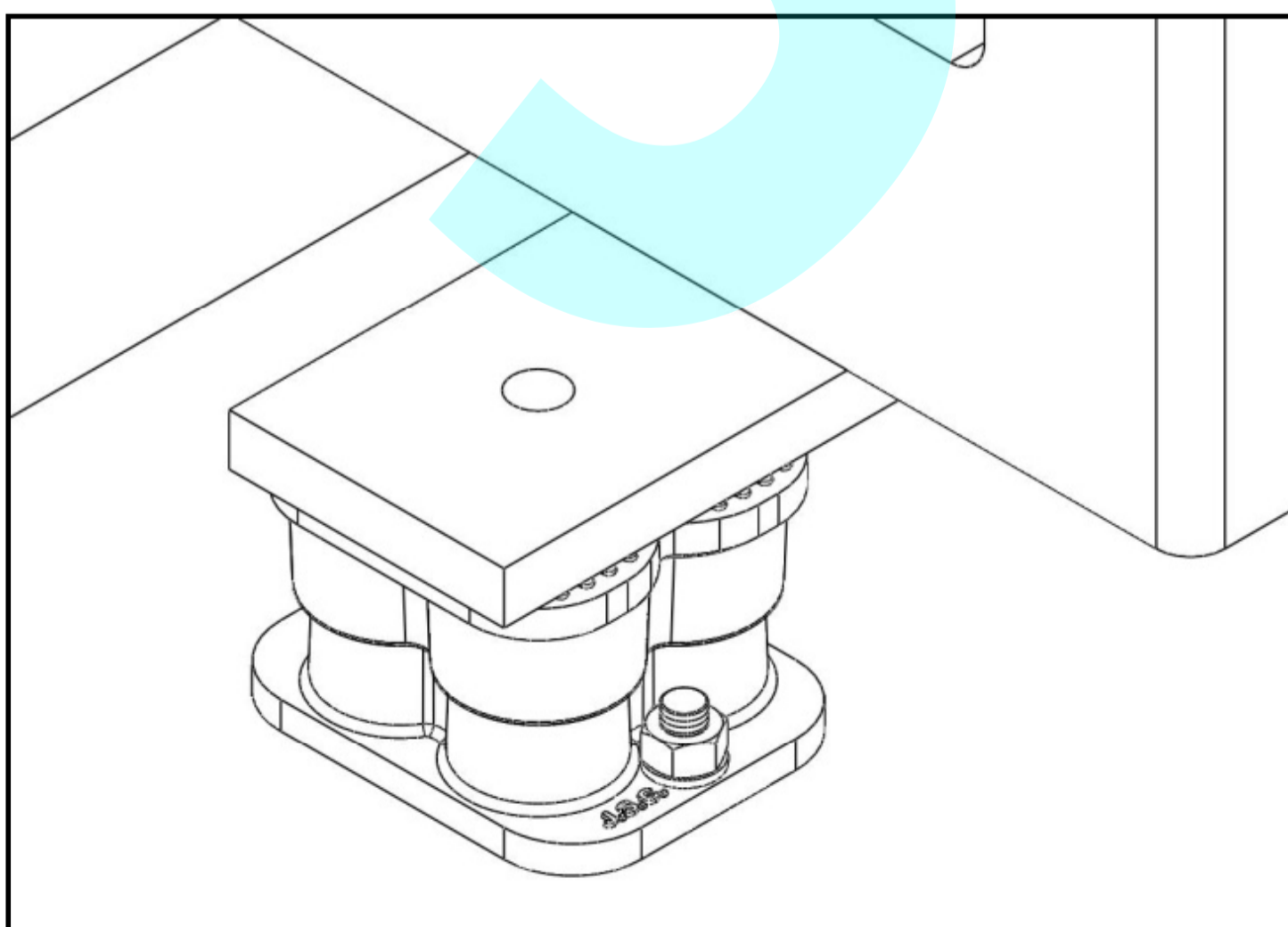
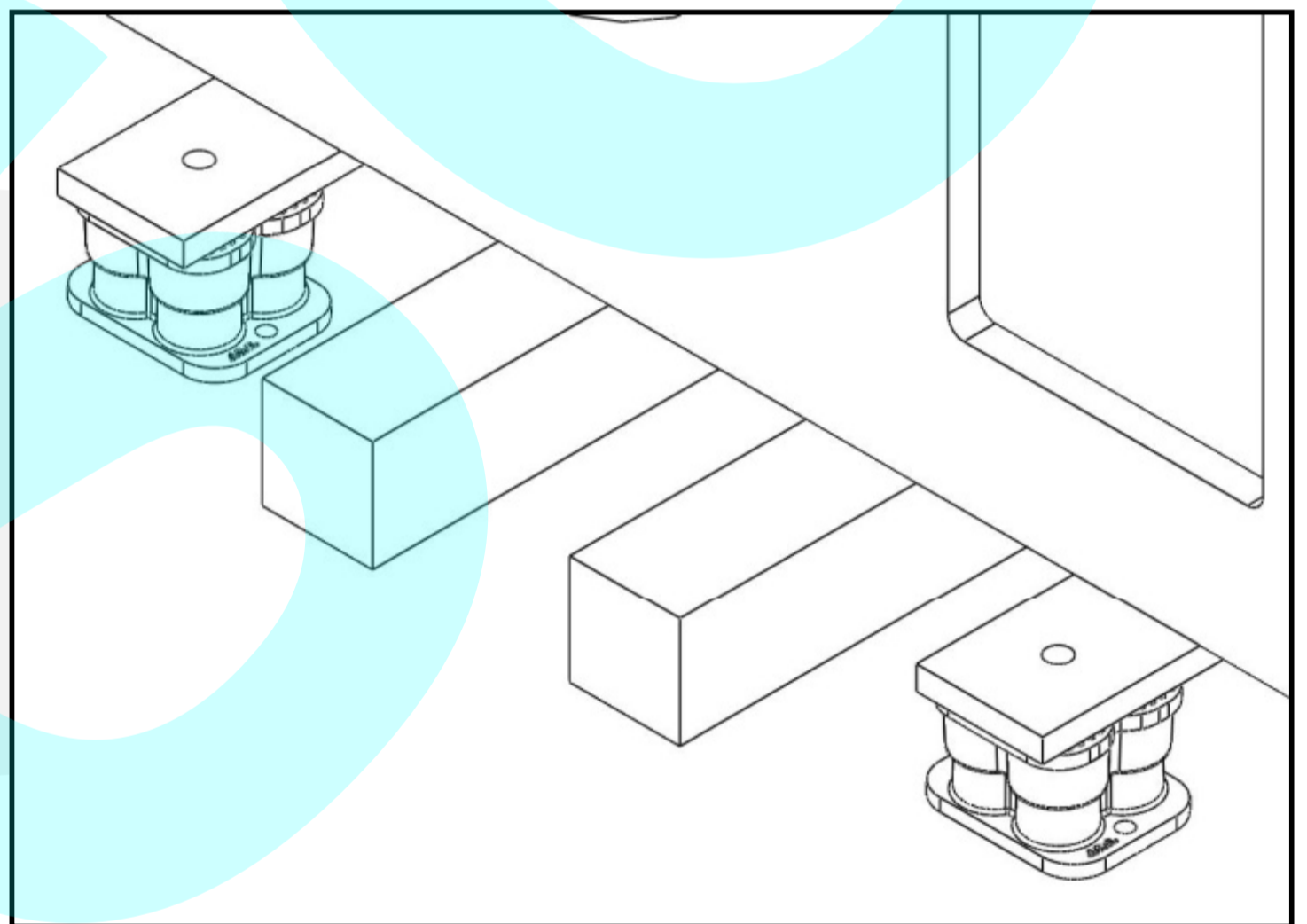

圖4)利用M10固定螺栓將設備與避震器略為鎖固。

Fig 4) Fasten the mounts and the equipment with M10 fixed bolt without locking them.

圖5)使用爪式千斤頂將設備下之臨時木台取出，此時避震器會下壓。

Fig 5) Apply claw jack to remove the wooden panel beneath the equipment and to press down the mounts.

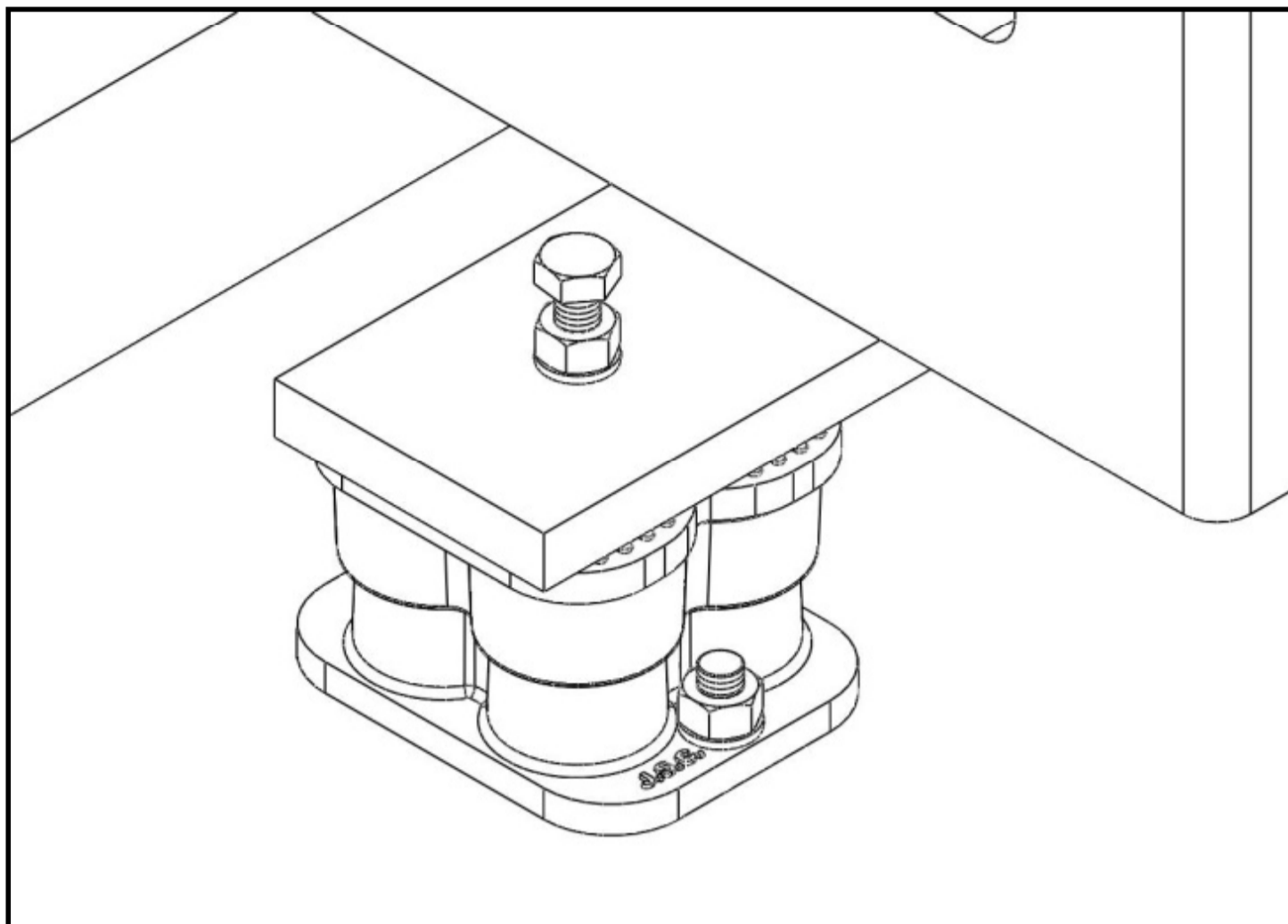
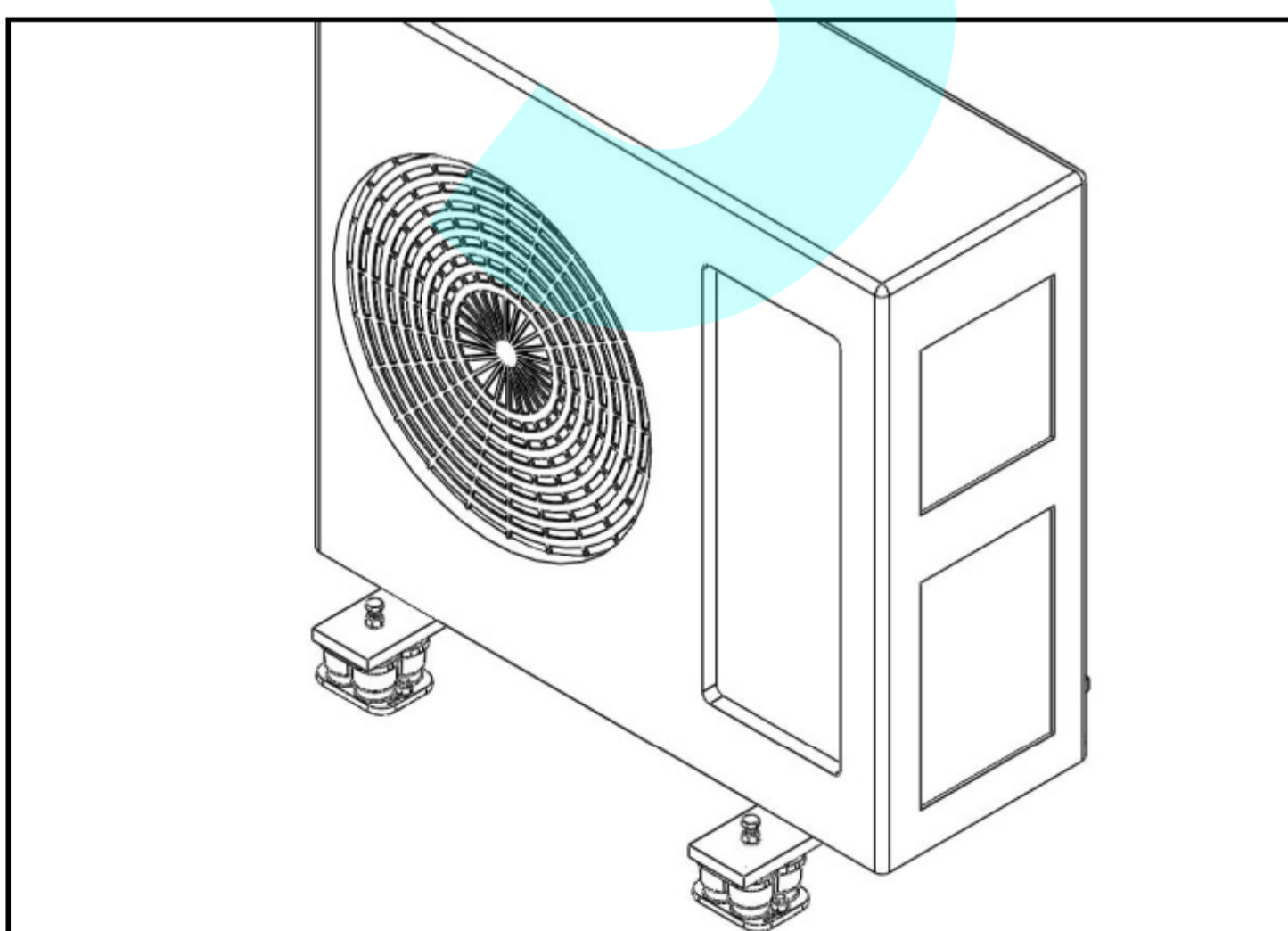
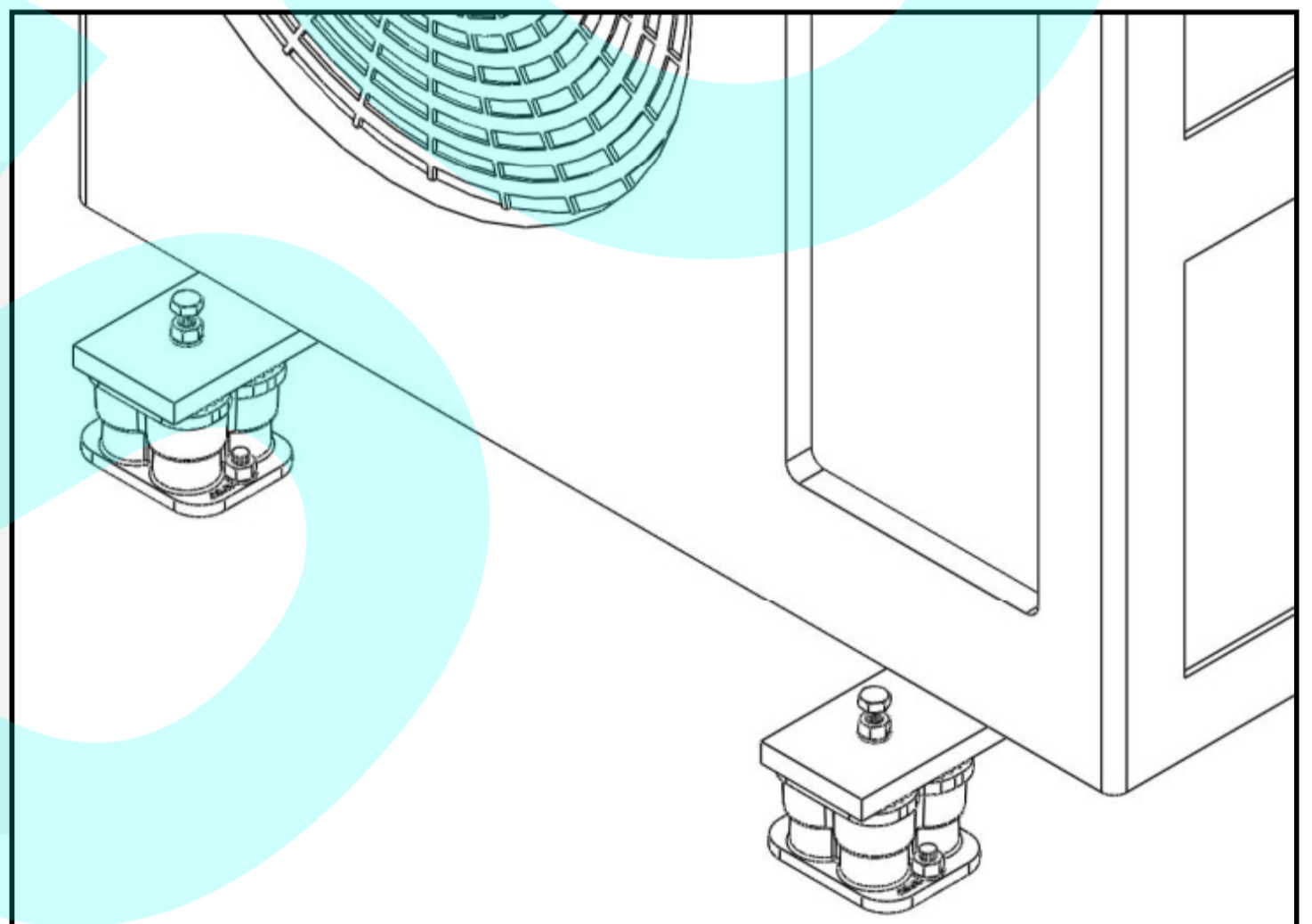

圖6)將固定螺栓與設備完全鎖緊後，即完成避震器安裝。

Fig 6) After the adjustment, lock the mounts with fixed bolt.