

JG-M 抗震型彈簧式避震器安裝說明

JG-M Seismic snubber spring mounts installation guide

安裝前，請確認避震器之型號規格是否正確。

Before installation, make sure the model and the specification are correct.

安裝說明

Installation guide

- 所需工具：公制口徑24mm (M16)開口扳手、爪式千斤頂。

Required tools: 24mm(M16) open wrench and claw jack.

- 可先行放置與避震器高度相同的臨時木台於設備安裝處，再安裝設備。(如圖1)

Place the wooden panel with the same height as the mounts on the installation before installing (Fig 1).

- 將避震器放置於與設備的正確安裝位置，並以基礎螺栓固定。(如圖2)

Place the mounts on the installation location and fasten it with foundation bolt (Fig 2).

- 以M16固定螺栓將避震器與設備固定，但不鎖緊。(如圖3)

Fasten the mounts and the equipment with M16 fixed bolt without locking them (Fig 3).

- 使用公制口徑24mm開口扳手以順時針方向調整螺帽使彈簧受力下壓。(如圖4)

Adjust the adjustment nuts in the clockwise direction with 24mm open wrench to press down the spring (Fig 4).

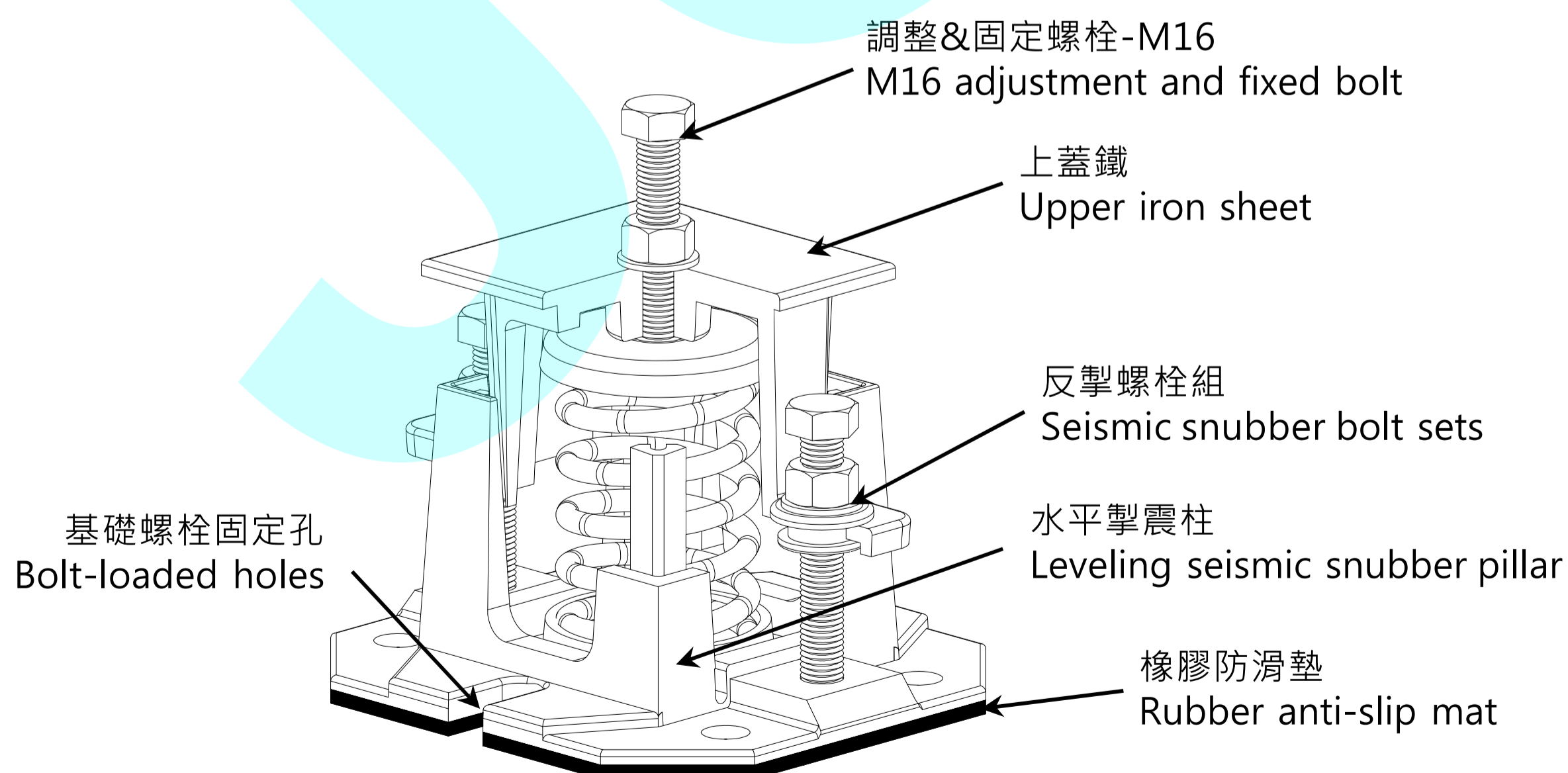
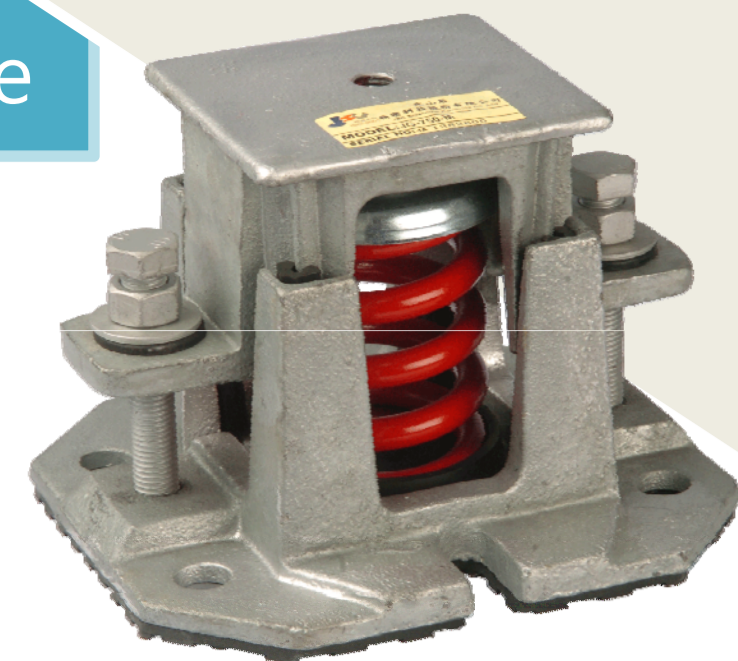

JG-M 抗震型彈簧式避震器安裝說明

JG-M Seismic snubber spring mounts installation guide

安裝說明

Installation guide

- 調整至避震器上蓋鐵上升，臨時木台可取出時即可停止調整。(如圖5)

Adjust until the upper iron sheet of the mounts arises. Adjustment can be stopped once the wooden panel is removed (Fig 5).

- 將M16固定螺栓確實與設備鎖緊，即完成避震器之安裝調整。(如圖6)

After the adjustment, lock the mounts with M16 fixed bolt (Fig 6).

- 安裝後請檢查彈簧之下壓量，如彈簧壓實表示荷重不足無避震效果。應予更換較大荷重之規格，並請洽本公司業務人員。

After the adjustment, check the press amount of the spring. If it appears with insufficient loading, please replace with bigger loading by contacting our staff.

- 安裝時，請注意安全。

Be cautious during the installation.

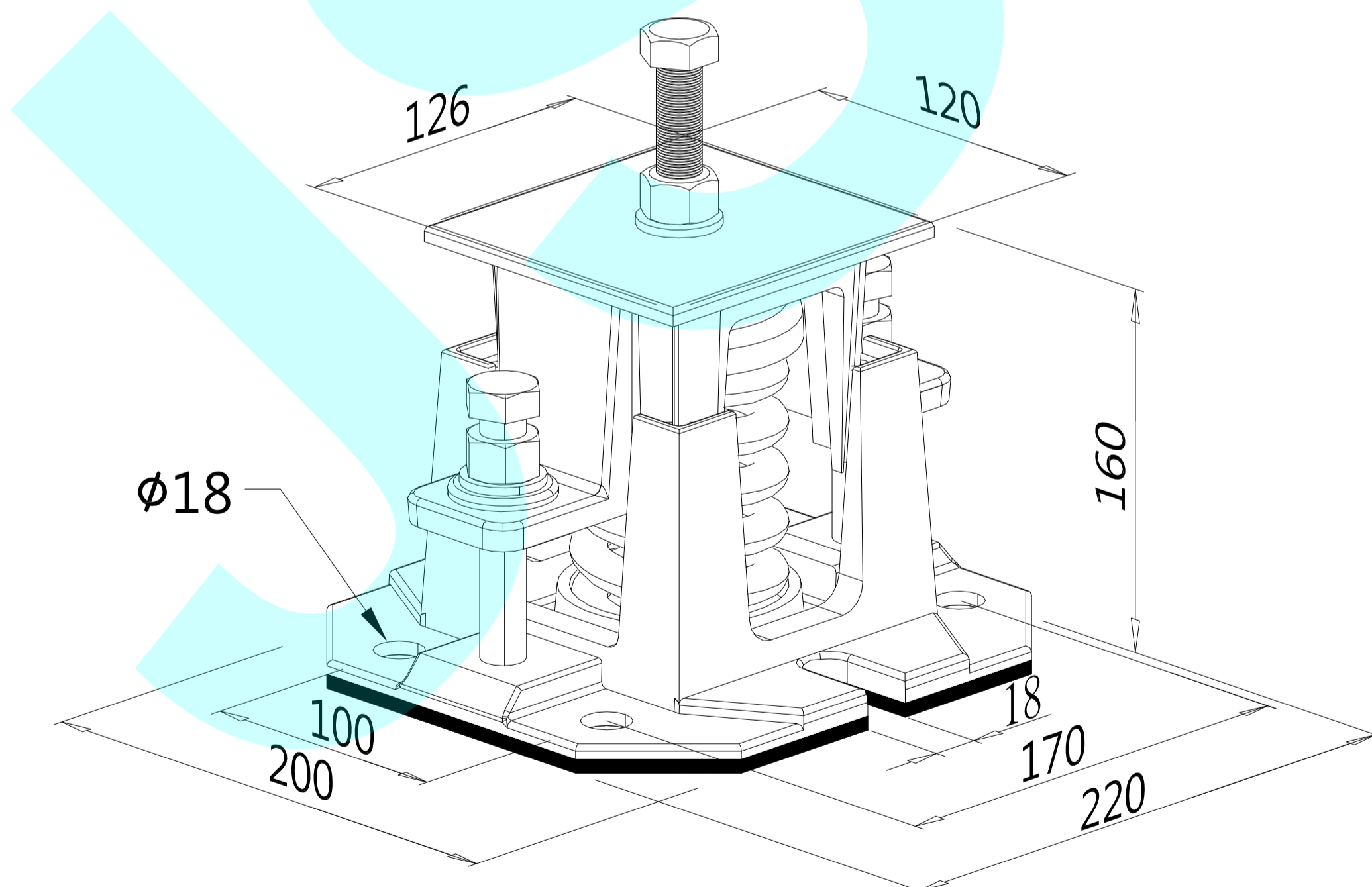
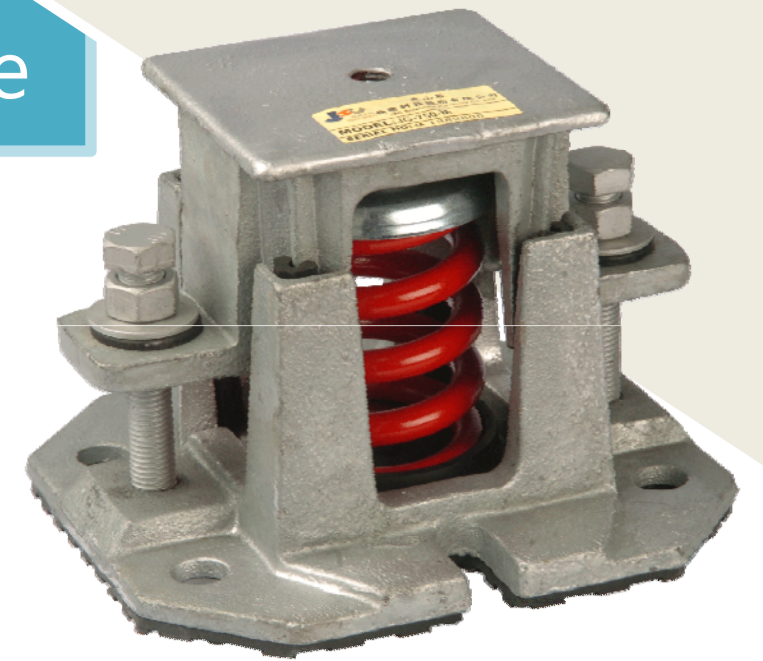

※ 保養點檢項目：每月觀察固定螺栓&基礎螺栓保持鎖固、保持避震器安裝狀態&彈簧下壓撓度正常。

Maintenance checking points: remain fixed bolt and foundation bolt locked, installation of the mounts, and the deflection of the spring monthly.

JG-M 抗震型彈簧式避震器圖解說明

JG-M Seismic snubber spring mounts illustration



圖1) 安裝設備時可先放置與避震器相同高度之臨時木台。

Fig 1) Place the wooden panel with the same height as the mounts on the installation before installing.

圖2) 將避震器放置於設備避震器安裝位置處，並以基礎螺栓固定。

Fig 2) Place the mounts on the installation location and fasten it with foundation bolt.

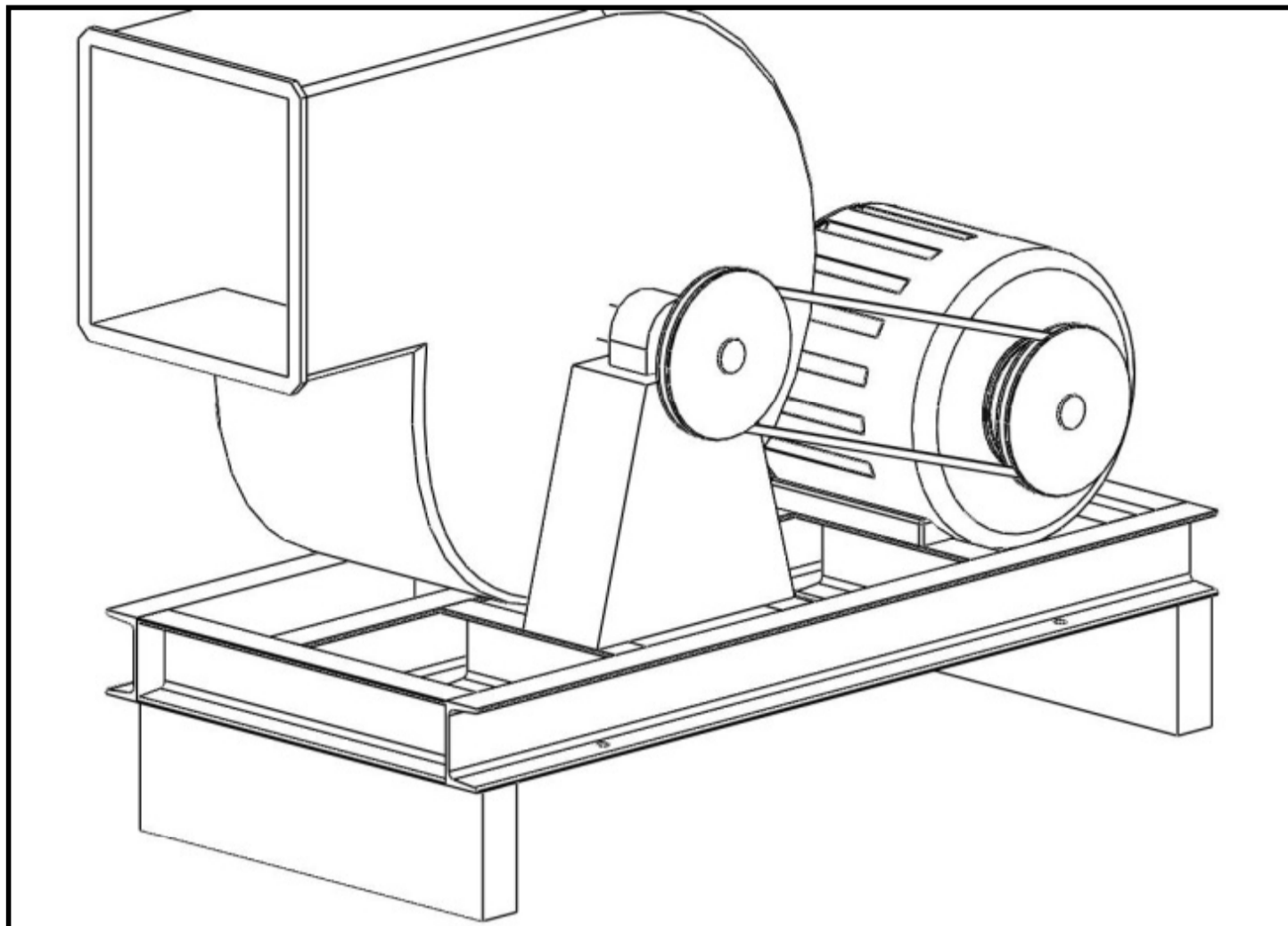

圖3) 以M16固定螺栓將避震器與設備固定，但不鎖緊。

Fig 3) Fasten the mounts and the equipment with M16 fixed bolt without locking them.

JG-M 抗震型彈簧式避震器圖解說明 JG-M Seismic snubber spring mounts illustration

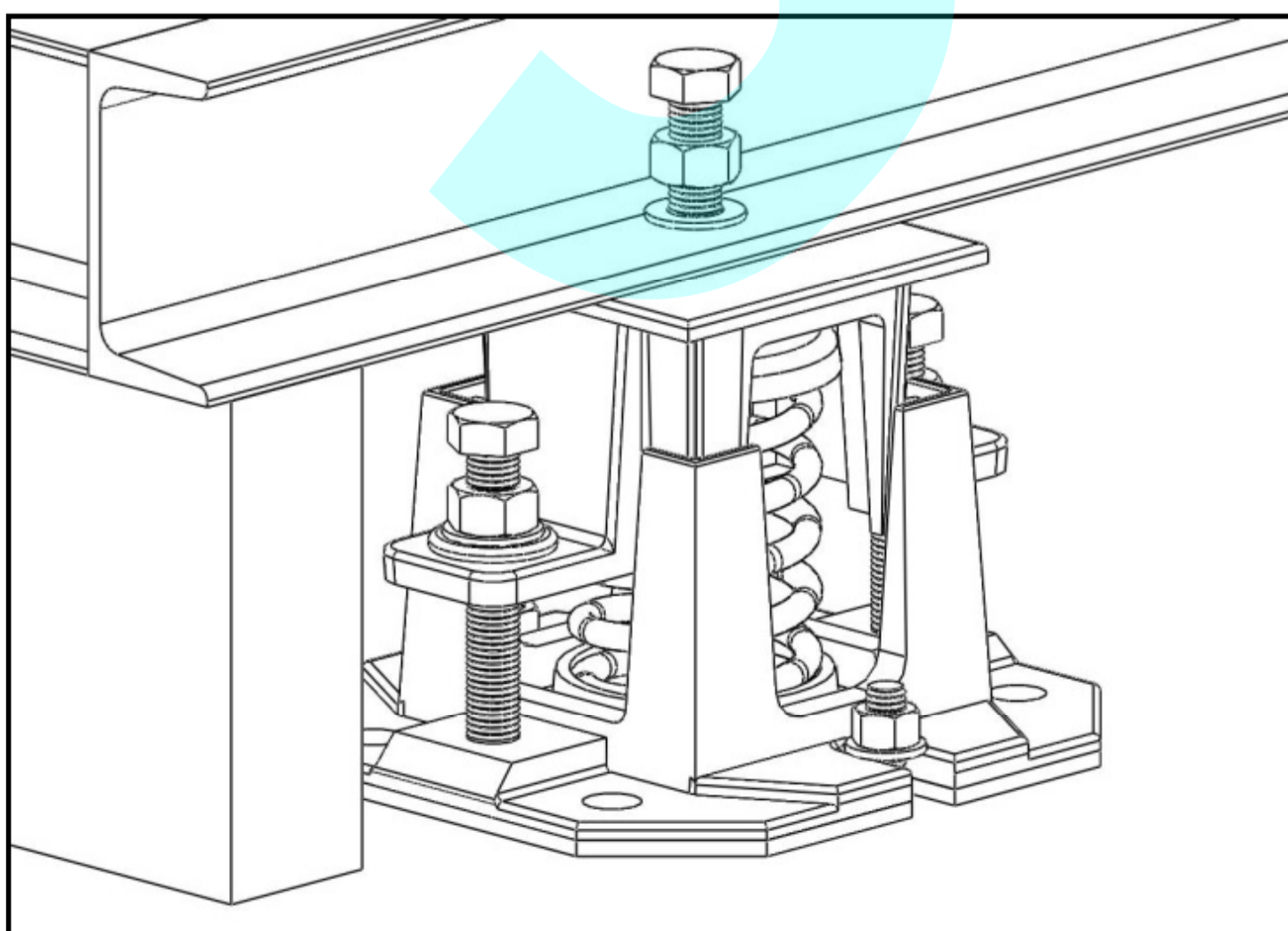
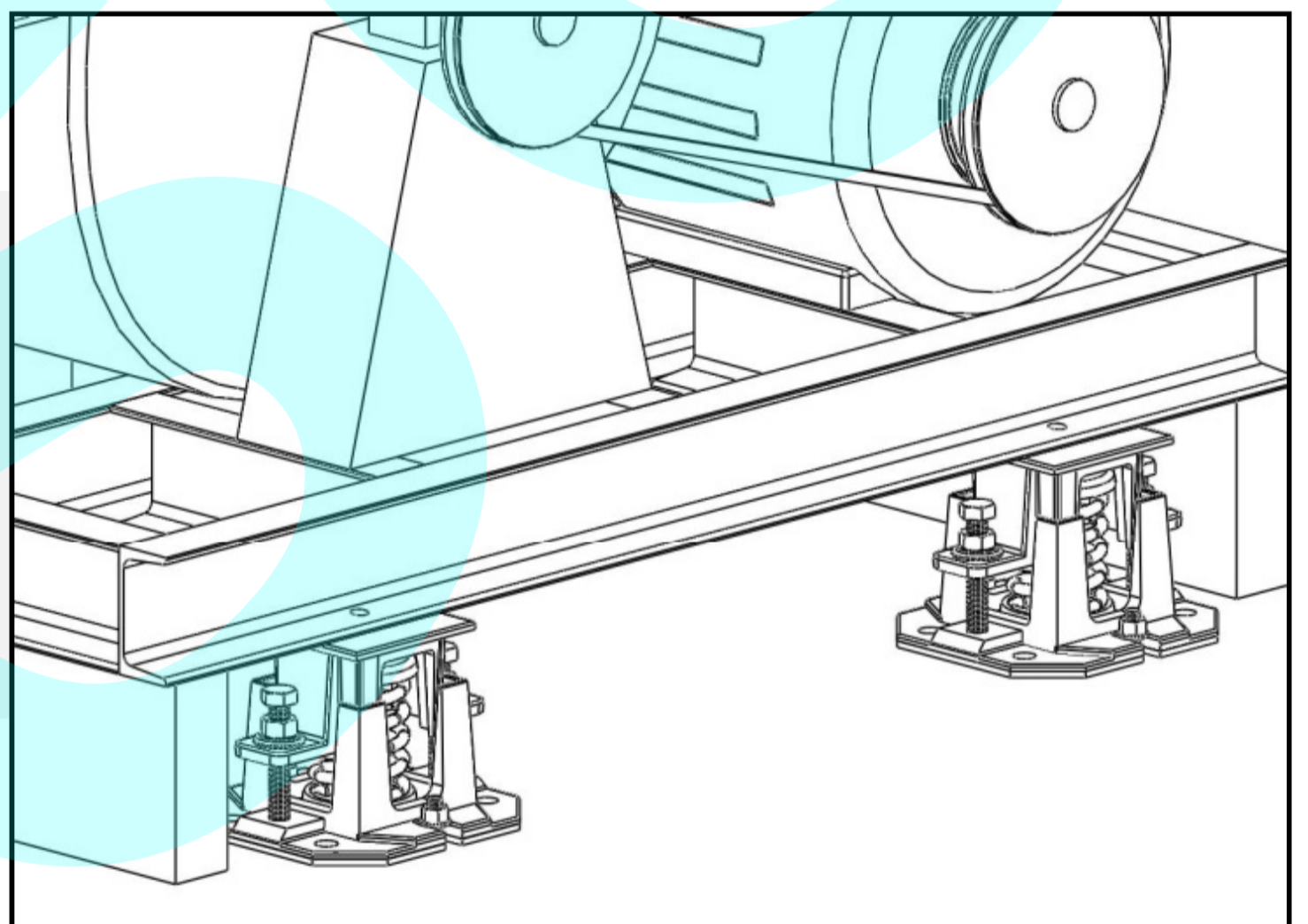

圖4)使用公制口徑24mm板手以順時針方向調整螺栓，使彈簧下壓。

Fig 4) Adjust the adjustment bolts in the clockwise direction with 24mm open wrench to press down the spring.

圖5)調整至彈簧下壓及避震器上蓋鐵昇高，木台可以取出時即可完成調整。

Fig 5) Adjust until the spring is down and the upper iron sheet of the mounts arises. Adjustment can be stopped once the wooden panel is removed.

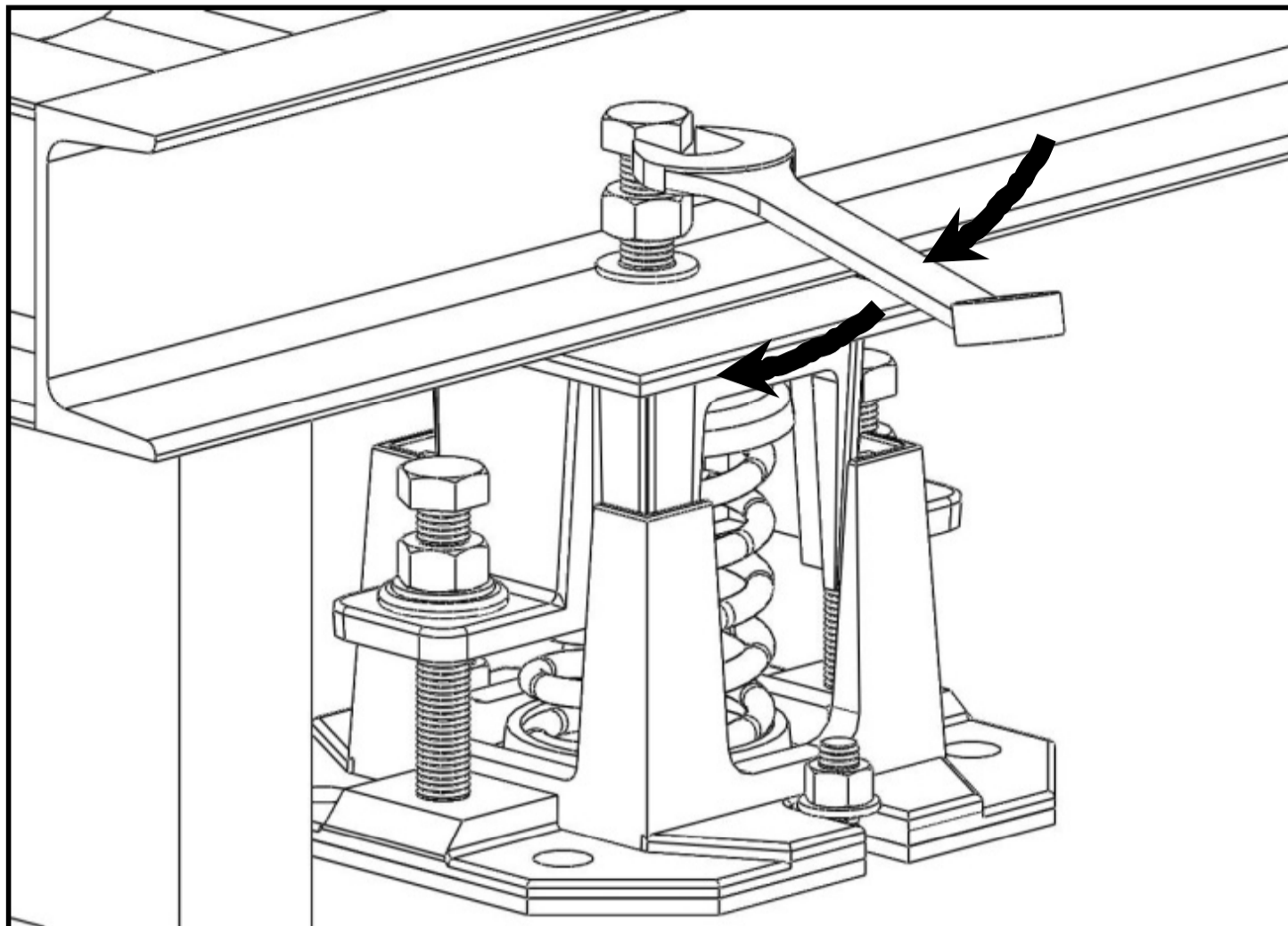
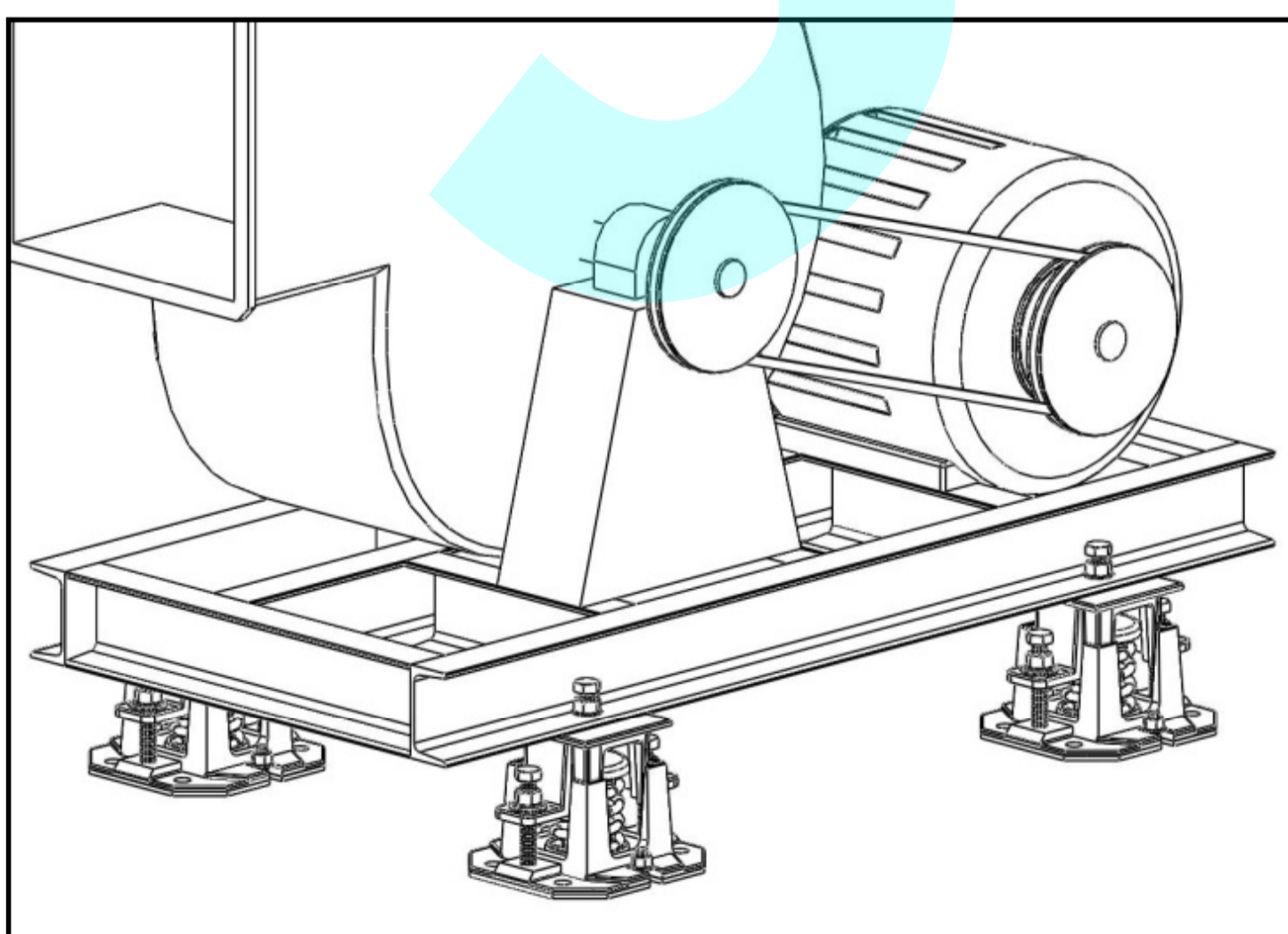
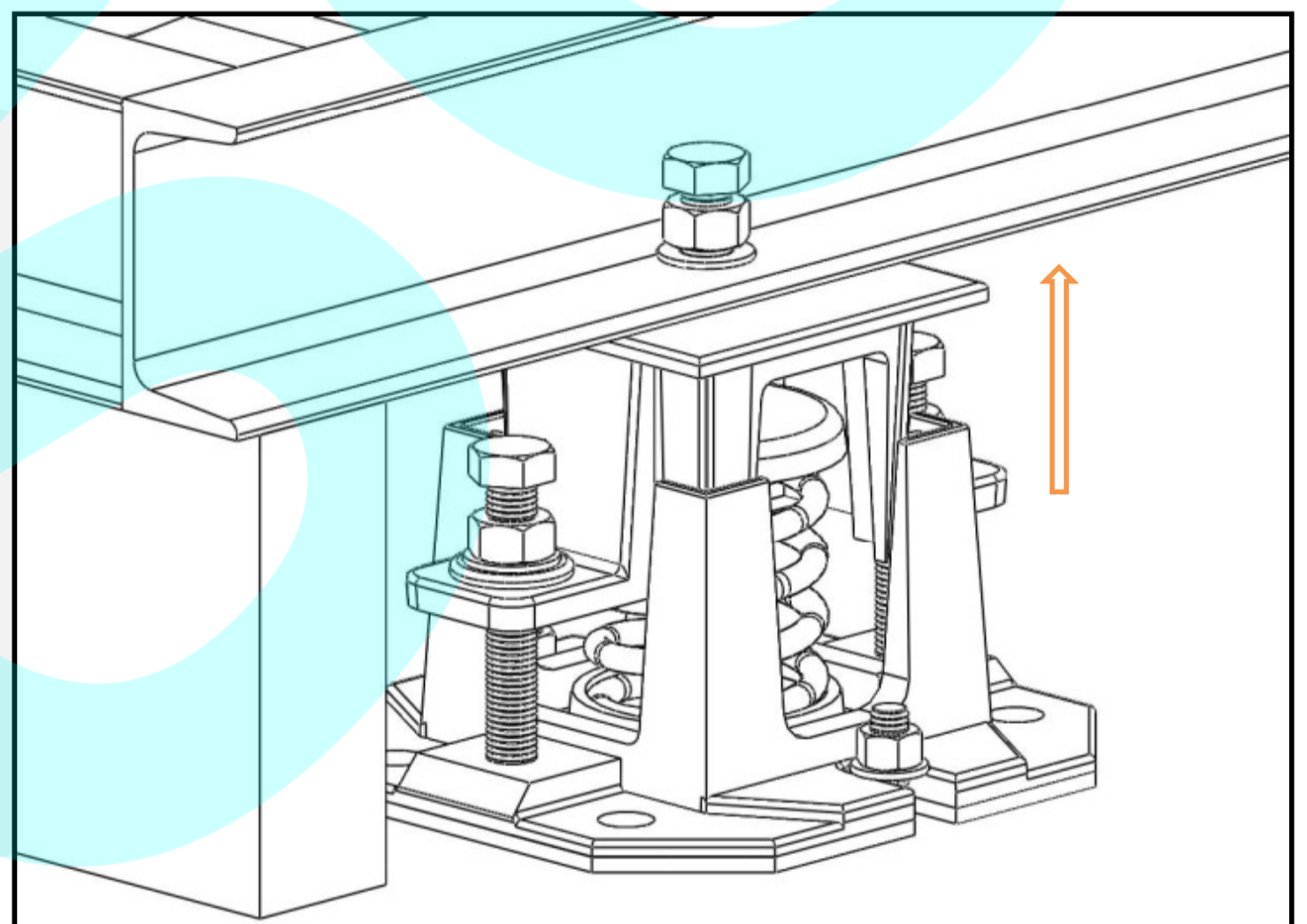

圖6)將M16螺栓與設備完全鎖緊後，即完成避震器安裝調整。

Fig 6) After the adjustment, lock the mounts with M16 fixed bolt.