

JG 抗震型彈簧式避震器安裝說明

Seismic snubber spring mounts installation guide

安裝前，請確認避震器之型號規格是否正確。

Before installation, make sure the model and the specification are correct.

安裝說明

Installation guide

- 所需工具：公制口徑19mm (M12)、24mm (M16)、30mm (M20)、32mm (M22)開口扳手、爪式千斤頂。

Required tools: 19mm (M12) 24mm (M16) and 32mm (M22) open wrenches and claw jack.

- 可先行放置與避震器高度相同的臨時木台於設備安裝處，再安裝設備。(如圖1)

Place the wooden panel with the same height as the mounts on the installation before installing (Fig 1).

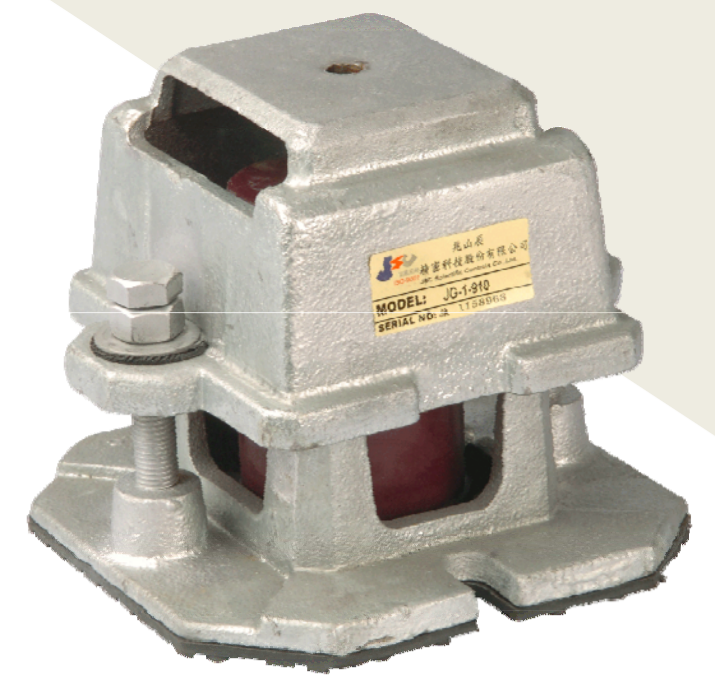

型號 Type	尺寸 Dimension(mm)										
	L	W	A	B	L1	W1	L2	W2	H	ψBD	CS
JG-1	210	210	186	*	117	97	*	*	190	16	M12
JG-2	240	330	270	*	107	227	80	130	190	20	M16
JG-4	280	370	300	60	195	205	130	130	190	20	M20

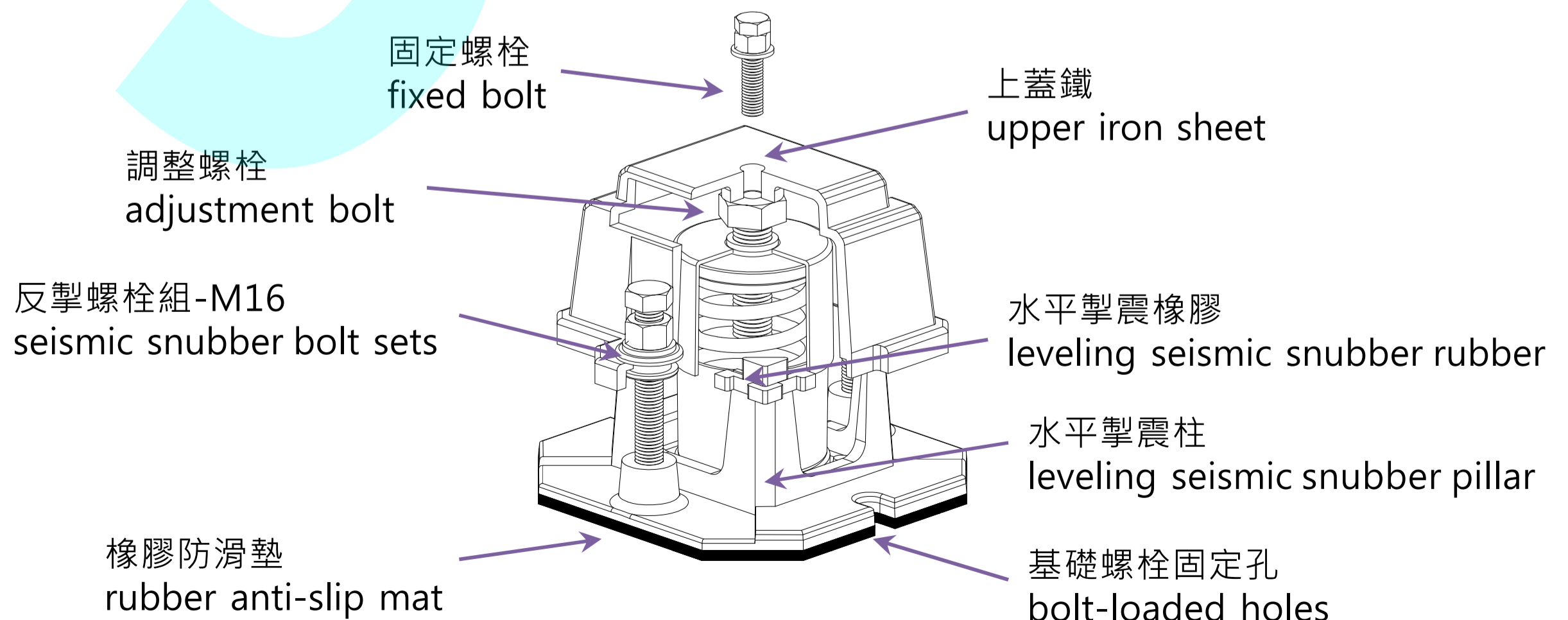
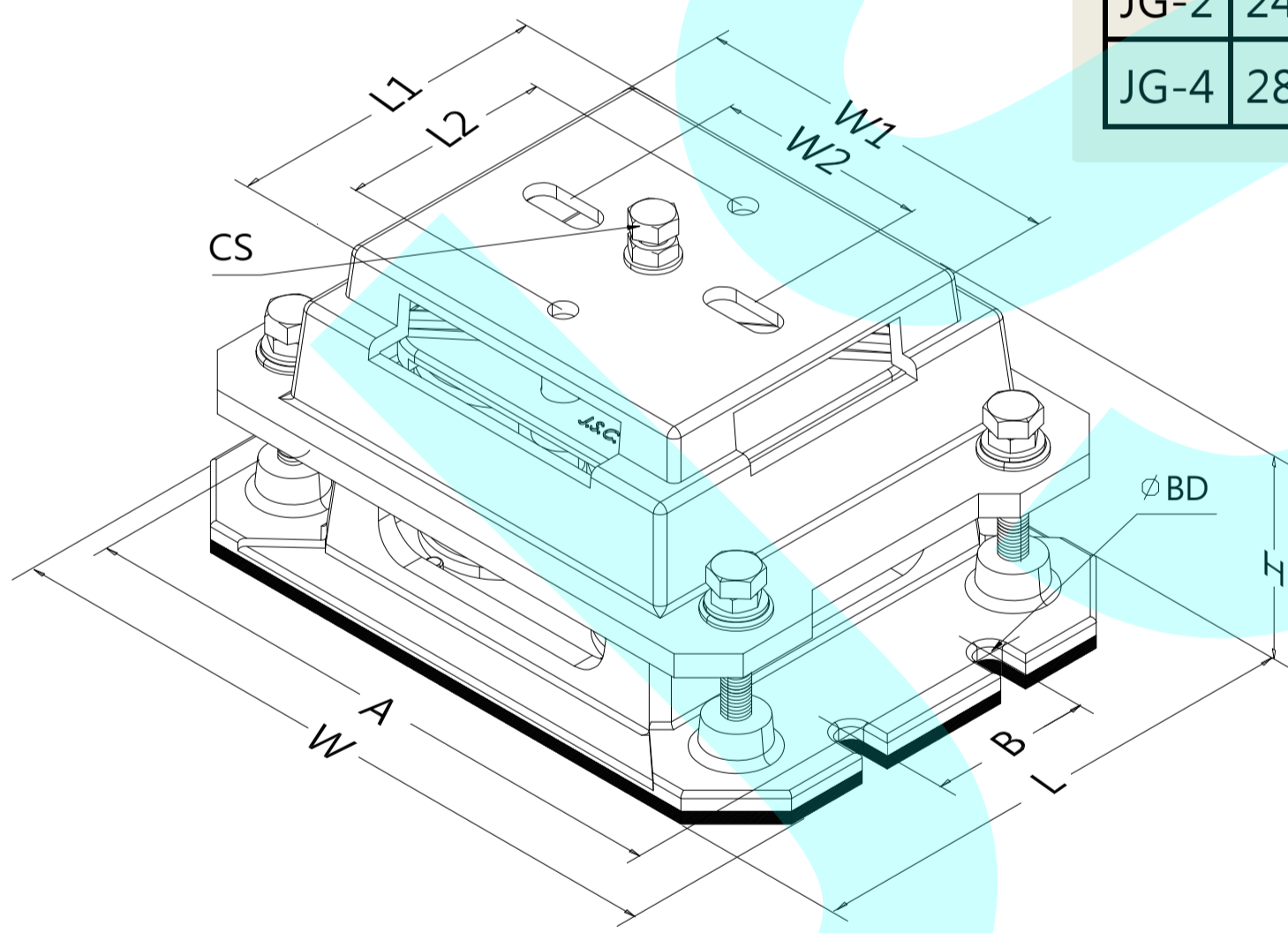

JG 抗震型彈簧式避震器安裝說明

Seismic snubber spring mounts installation guide

安裝說明

Installation guide

- 依據基礎螺栓固定孔的位置，於安裝位置預埋基礎螺栓。

Embed foundation bolts according to the location of bolt-loaded holes.

- 先將定位鉚釘拿掉。(如圖2)

Remove quilting rivet (Fig 2)

- 將避震器放置於正確安裝位置，以固定螺栓將避震器與設備固定，但不鎖緊。(如圖3)

Place the mounts to its location and fasten it on the base with fixed bolts without locking it (Fig 3).

- 將避震器使用基礎螺栓於安裝位置上。

Place the base on the installation location.

- 使用開口扳手以逆時針方向調整避震器內的調整螺栓，使彈簧受力下壓。(如圖4)

Adjust the adjustment bolts of the mounts in the anti-clockwise direction with the open wrench to press down the spring (Fig 4).

- 調整至避震器上蓋鐵上升，臨時木台可取出時即可停止調整。(如圖5)

Adjust until the upper iron sheet of the mounts arises. Adjustment can be stopped once the wooden panel is removed (Fig 5).

- 將固定螺栓確實與避震器鎖緊，即完成避震器之安裝調整。(如圖6)

Lock the mounts with fixed bolt to complete the installation (Fig 6).

- 安裝後請檢查彈簧之下壓量，如彈簧壓實表示荷重不足無避震效果。應予更換較大荷重之規格，並請洽本公司業務人員。

After the adjustment, check the press amount of the spring. If it appears with insufficient loading, please replace with bigger loading by contacting our staff.

- 安裝時，請注意安全。

Be cautious during the installation.

※ 保養點檢項目：每月觀察固定螺栓&基礎螺栓保持鎖固、保持避震器安裝狀態&彈簧下壓撓度正常。

Maintenance checking points: remain fixed bolt and foundation bolt locked, installation of the mounts, and the deflection of the spring monthly.

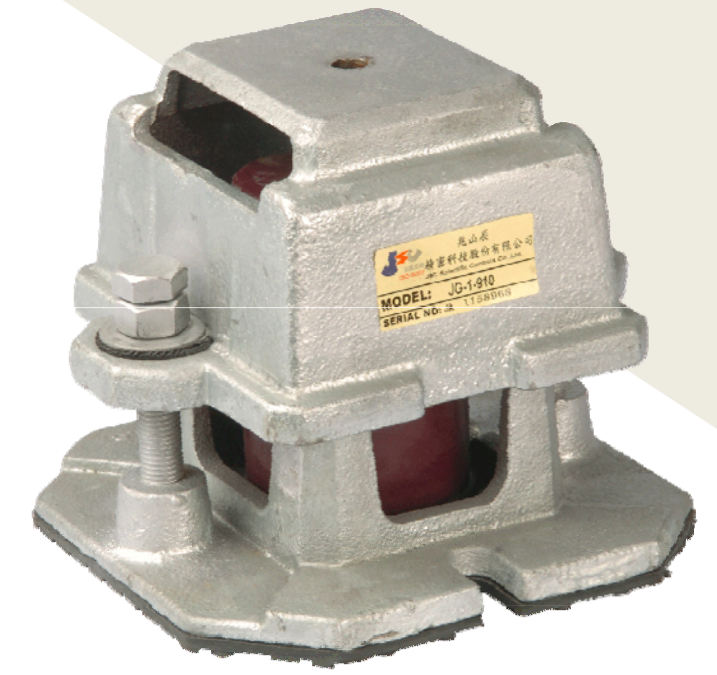

JG 抗震型彈簧式避震器圖解說明

JG seismic snubber spring mounts illustration



圖1)安裝設備時可先放置與避震器相同高度之臨時木台。

Fig 1) Place the wooden panel with the same height as the mounts on the installation before installing.

圖2)將定位鉚釘取出。

Fig 2) Remove quilting rivet.

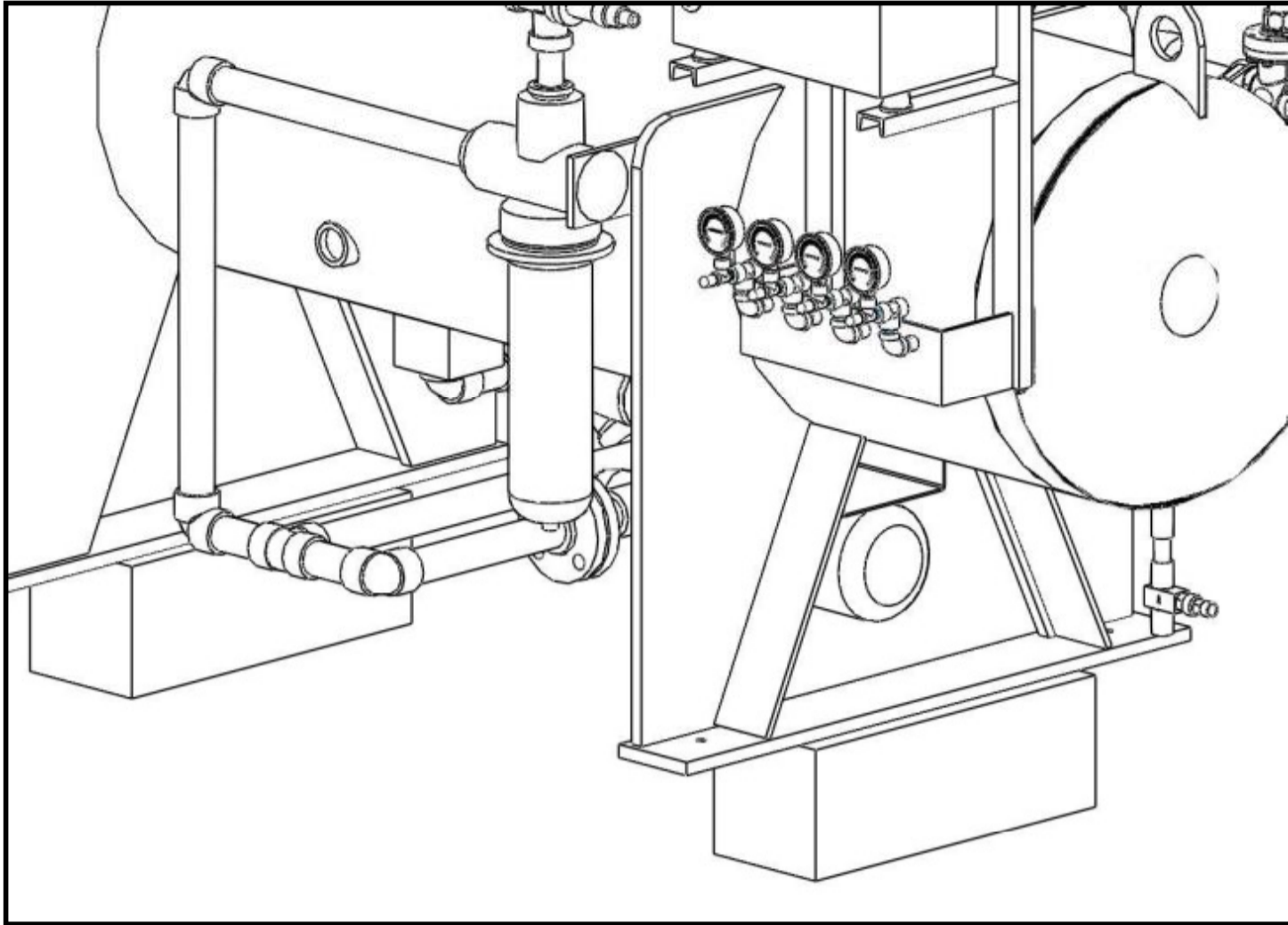

圖3)以固定螺栓將避震器與設備固定，但不鎖；同時以基礎螺栓將避震器固定。

Fig 3) Fasten the mounts and equipment with fixed bolts without locking them. Apply foundation bolts to fix the mounts.

JG 抗震型彈簧式避震器圖解說明

JG seismic snubber spring mounts illustration

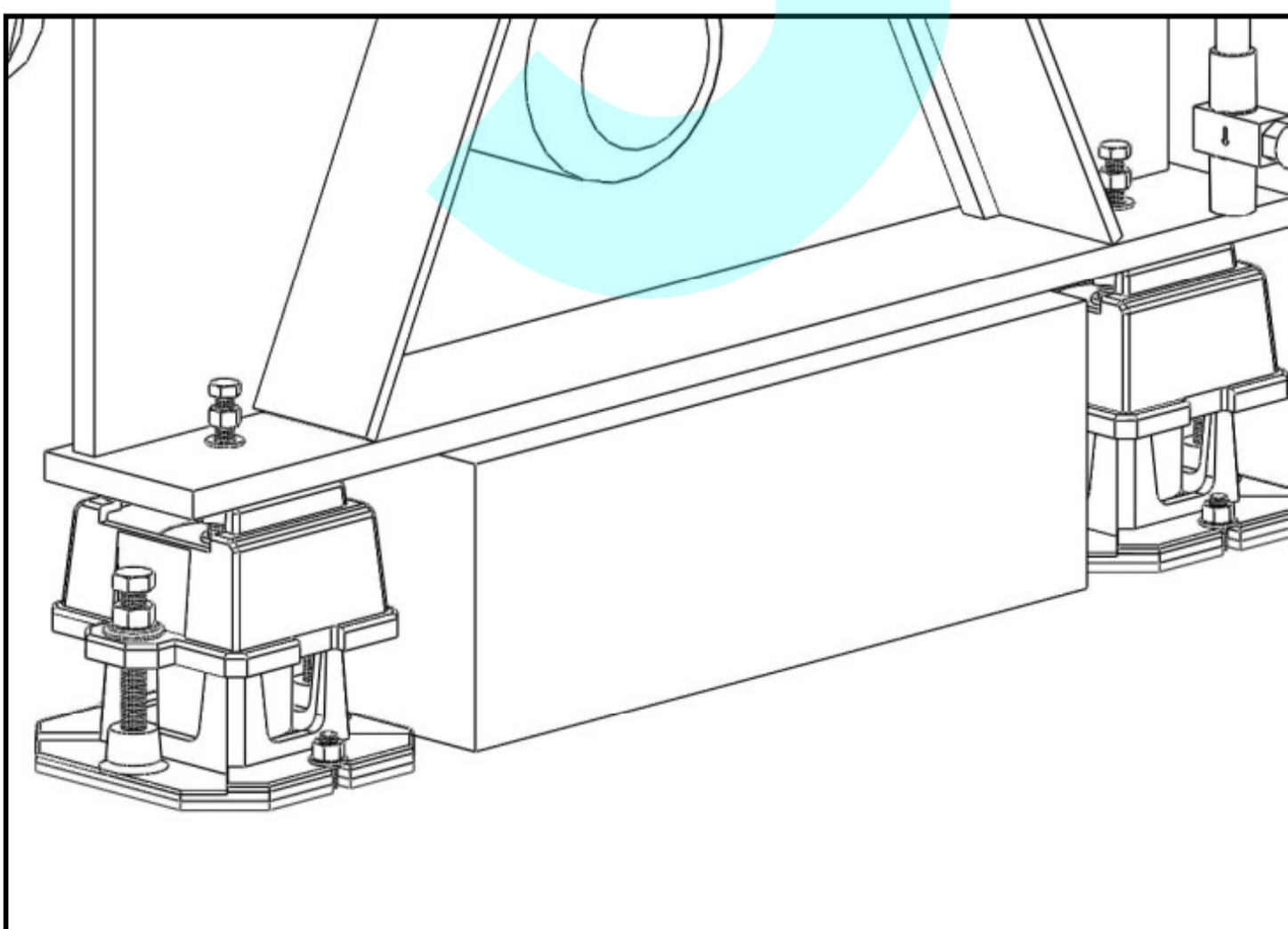
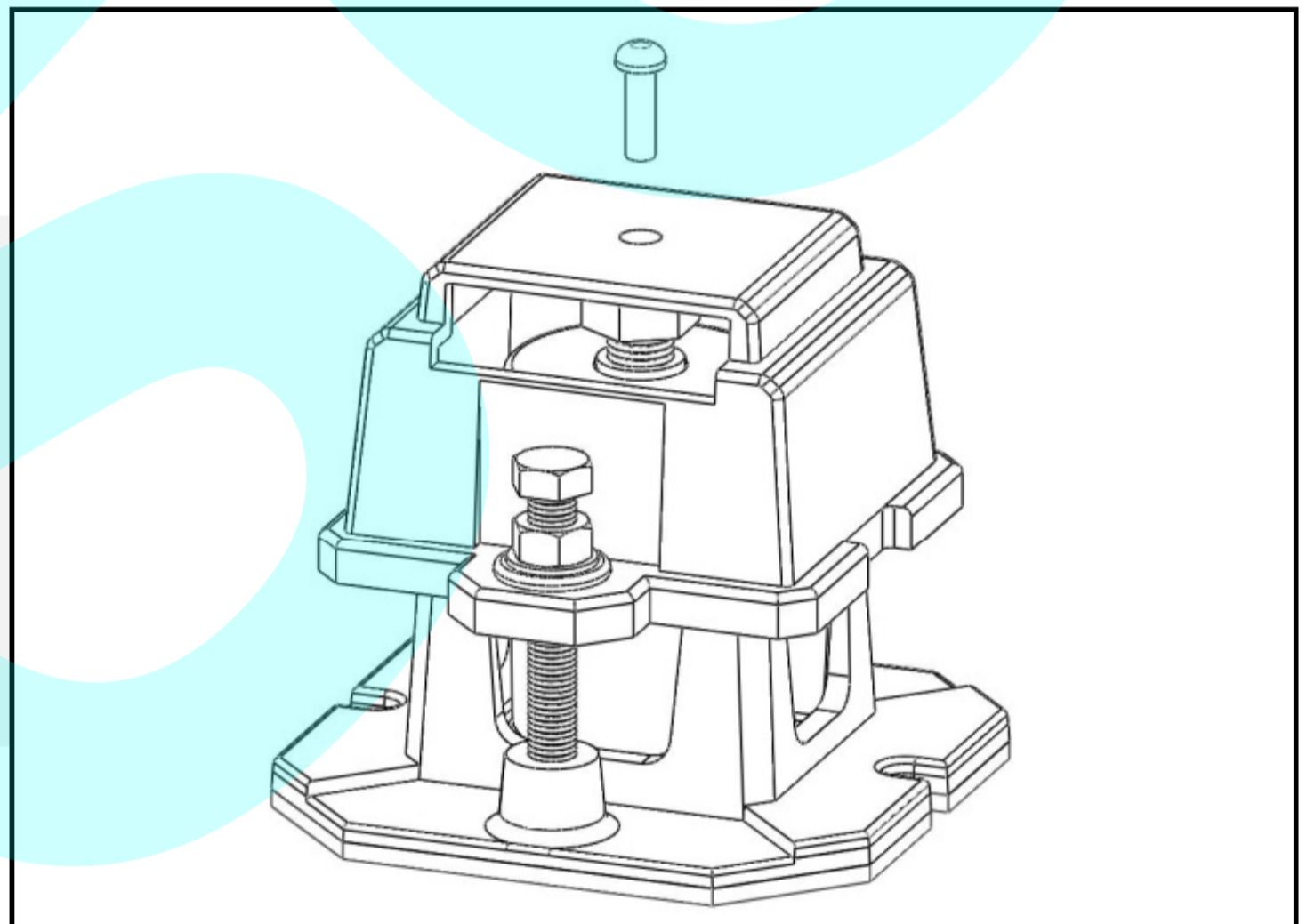

圖4)使用開口扳手以逆時針方向調整螺栓，緊使彈簧受力下壓。

Fig 4) Adjust the adjustment bolts of the mounts in the anti-clockwise direction with the open wrench to press down the spring.

圖5)調整至避震器上蓋鐵昇高，臨時木台可以取出時即可完成調整。

Fig 5) Adjust until the iron sheet of the mounts arises. Adjustment can be stopped once the wooden panel is removed (Fig 5).

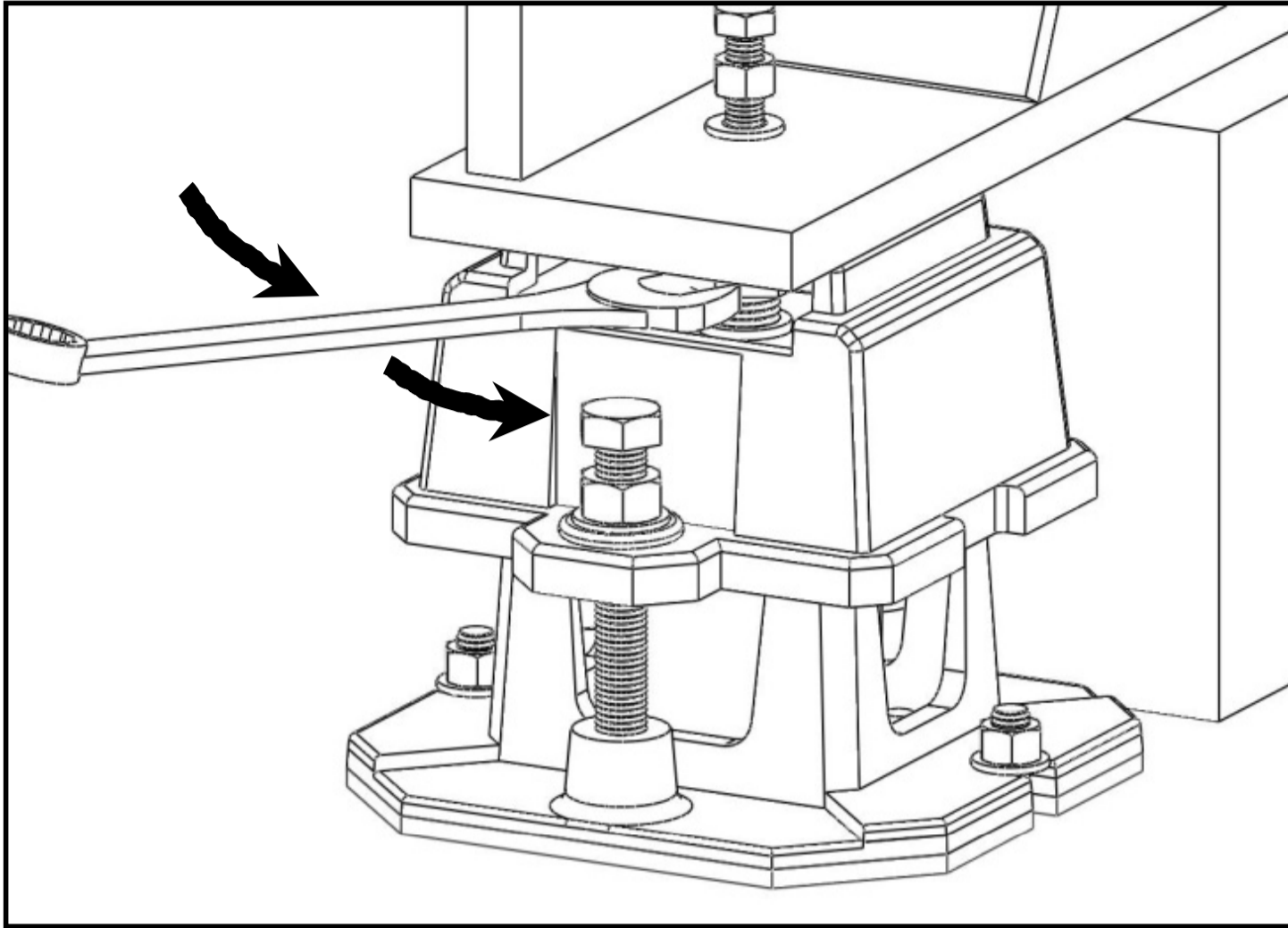
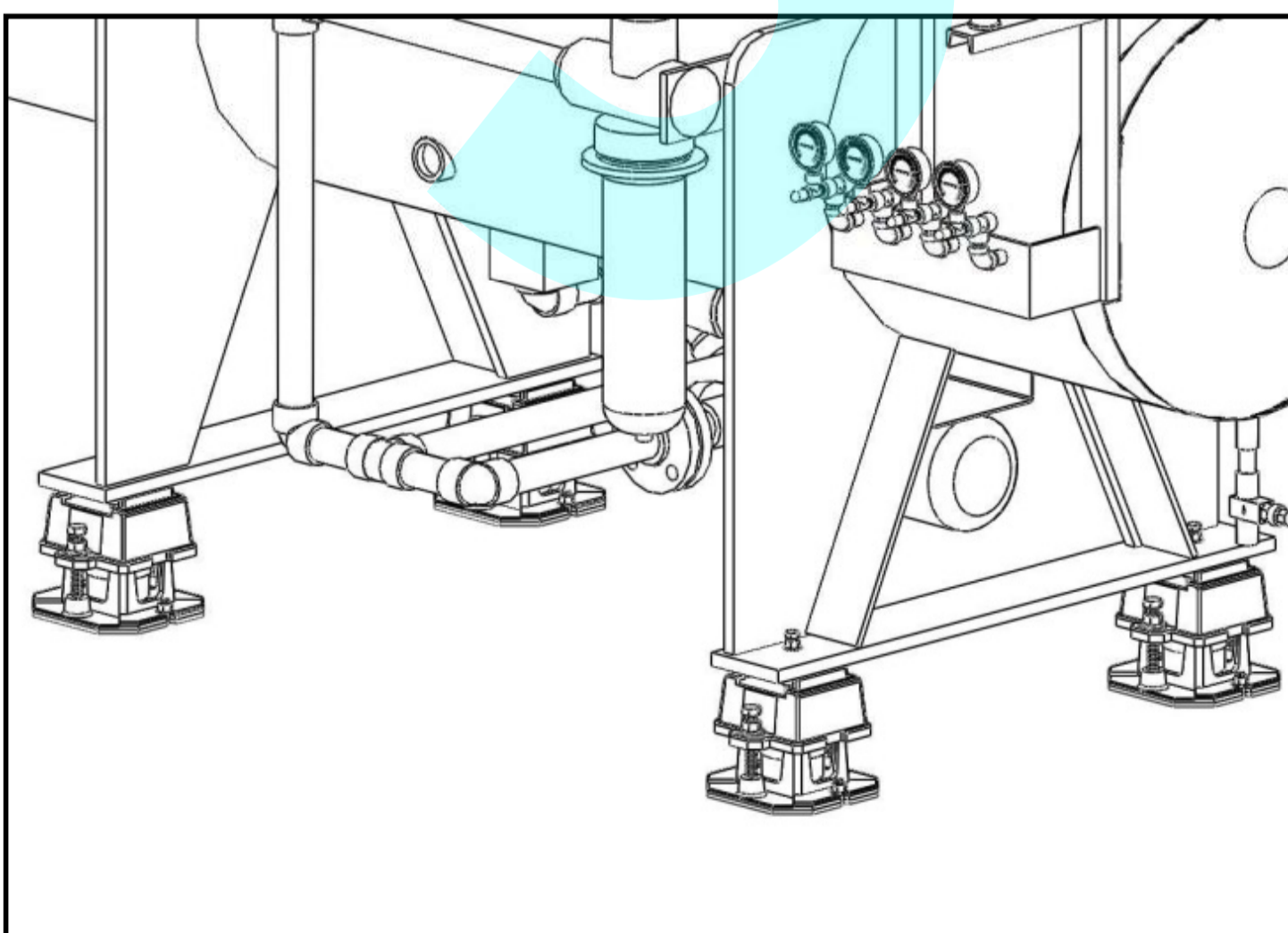
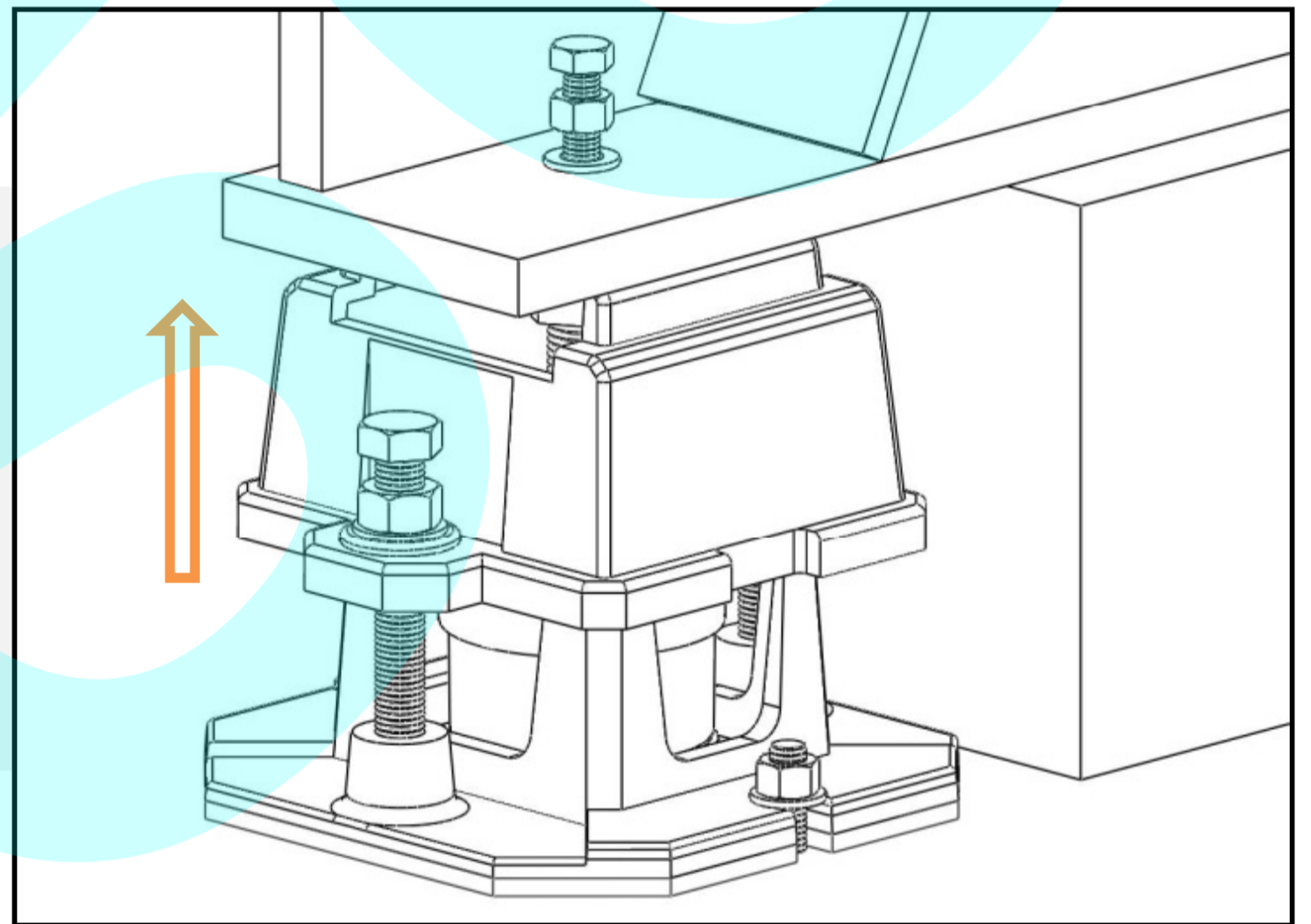

圖6)將固定螺栓與設備完全鎖緊後，即完成避震器安裝調整。

Fig 6) Lock the mounts with fixed bolt to complete the installation.