

JD 型彈簧式避震器安裝說明

JD spring isolator installation guide

安裝前，請確認避震器之型號規格是否正確。

Before installation, make sure the model and the specification are correct.

安裝說明

Installation guide

- 所需工具：公制口徑 19mm (M12)、32mm (M22)開口扳手、臨時木台(枕木)、爪式千斤頂。

Required tools: 19mm (M12) and 32mm (M22) open wrenches, wooden panel, and claw jack.

- 可先行放置與避震器高度相同的臨時木台於設備安裝處再安裝設備。(如圖1)

Place the wooden panel with the same height as the mounts on the installation before installing (Fig 1).

- 先將M22調整螺栓降到最低，以方便將避震器置入安裝位置。(如圖2)

Adjust M22 adjustment bolt to the lowest position to install the mounts (Fig 2).

- 依據基礎螺栓固定孔的位置，於安裝位置預埋基礎螺栓。

Embed foundation bolts according to the location of bolt-loaded holes.

- 將避震器放置於與設備的正確安裝位置。(如圖3)

Place the base on the installation location (Fig 3).



型號 Type	尺寸 Dimension (mm)					
	L	W	A	H	ψD	CS
JD-C	145	83	116	154	83	M12
JD-A	145	83	116	164	83	M12

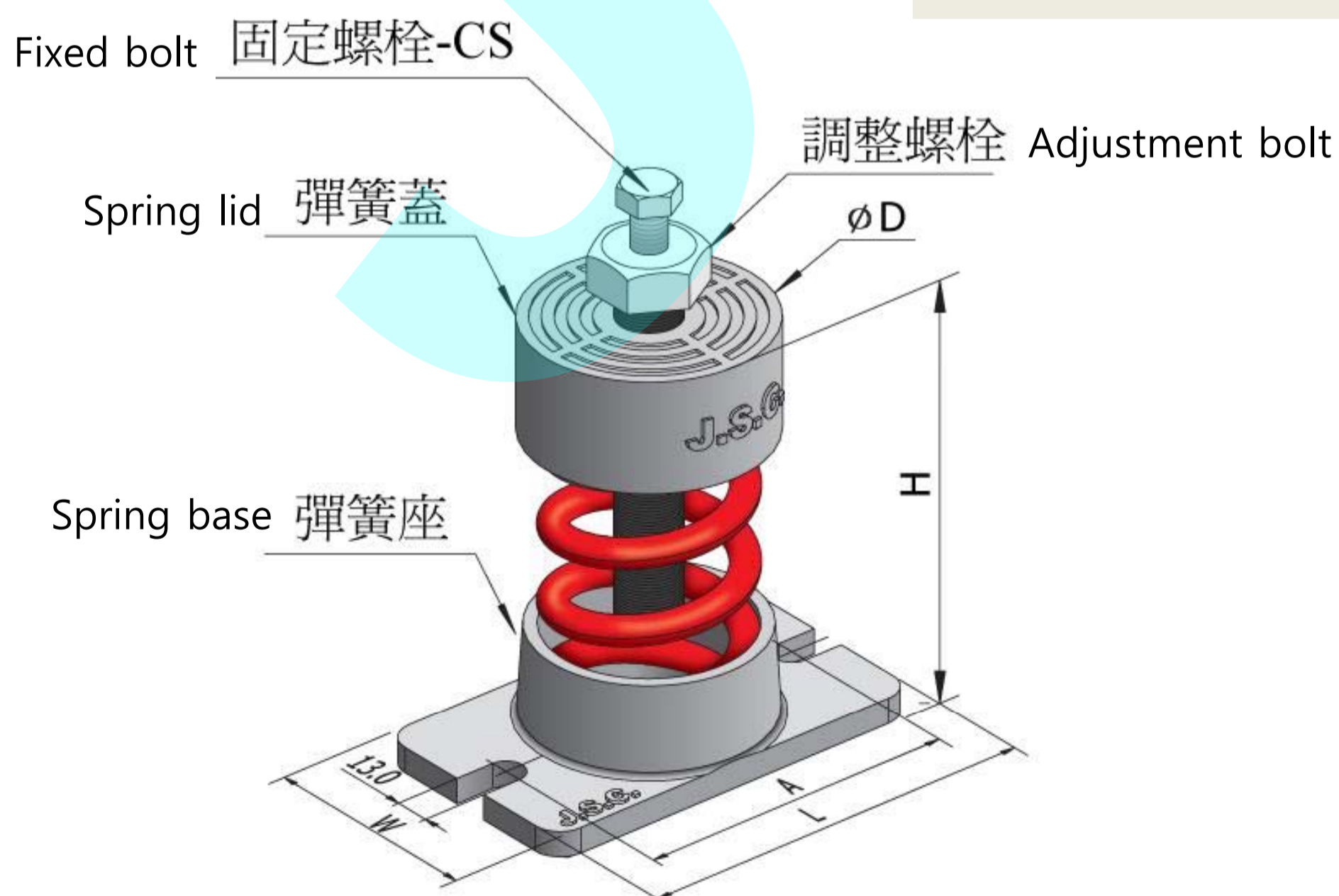

JD 型彈簧式避震器安裝說明 JD spring isolator installation guide

安裝說明

Installation guide

- 將JD型避震器置如安裝位置處，以M12固定螺栓將避震器與基座固定，但不鎖緊。(如圖4)



Place JD mounts to its location and fasten it on the base with M12 fixed bolts without locking it (Fig 4).

- 以公制口徑32mm開口扳手以逆時針方向調整M22調整螺栓，使彈簧受力下壓、基座上升；當壓塊可取出時即可停止調整，並將壓塊取出。(如圖5)

Adjust M22 adjustment bolt in the anti-clockwise direction with 32mm open wrench to press down the spring and to raise the base. Adjustment can be stopped once you can take out the briquetting (see Fig 5).

- 調整JD型避震器時需依序均勻調整各個避震器，勿一次調整以保持基座水平。

Adjust JD mounts in order and evenly while adjusting JC mounts to remain the balance of the base.

- 避震器未完成調整前，壓塊切勿強行取出。

Before completing the adjustment of the mounts, do not force to take out the briquetting.

- 調整完成後將M12固定螺栓確實與避震器完全鎖緊，即可完成避震器安裝調整。(如圖6)

After the adjustment, lock the mounts with M12 fixed bolt (Fig 6).

- 安裝後請檢查彈簧之下壓量，如彈簧壓實表示荷重不足無避震效果。應予更換較大荷重之規格，並請洽本公司業務人員。

After the adjustment, check the press amount of the spring. If it appears with insufficient loading, please replace with bigger loading by contacting our staff.

- 安裝時，請注意安全。

Be cautious during the installation.

※保養點檢項目：每月觀察固定螺栓&基礎螺栓保持鎖固、保持避震器安裝狀態&彈簧下壓撓度正常。

Maintenance checking points: Check the mounting bolts, remain fixed bolt locked, installation of the isolator, and the deflection of the spring.

JD 型彈簧式避震器圖解說明 JD spring isolator illustration



圖1) 安裝設備時可先放置與避震器相同高度之臨時木台。

Fig 1) Place the wooden panel with the same height as the mounts on the installation before installing.

圖2) 先將M22調整螺栓降到最低，以方便將避震器置入安裝位置以利安裝。

Fig 2) Adjust M22 adjustment bolt to the lowest position to install the mounts.

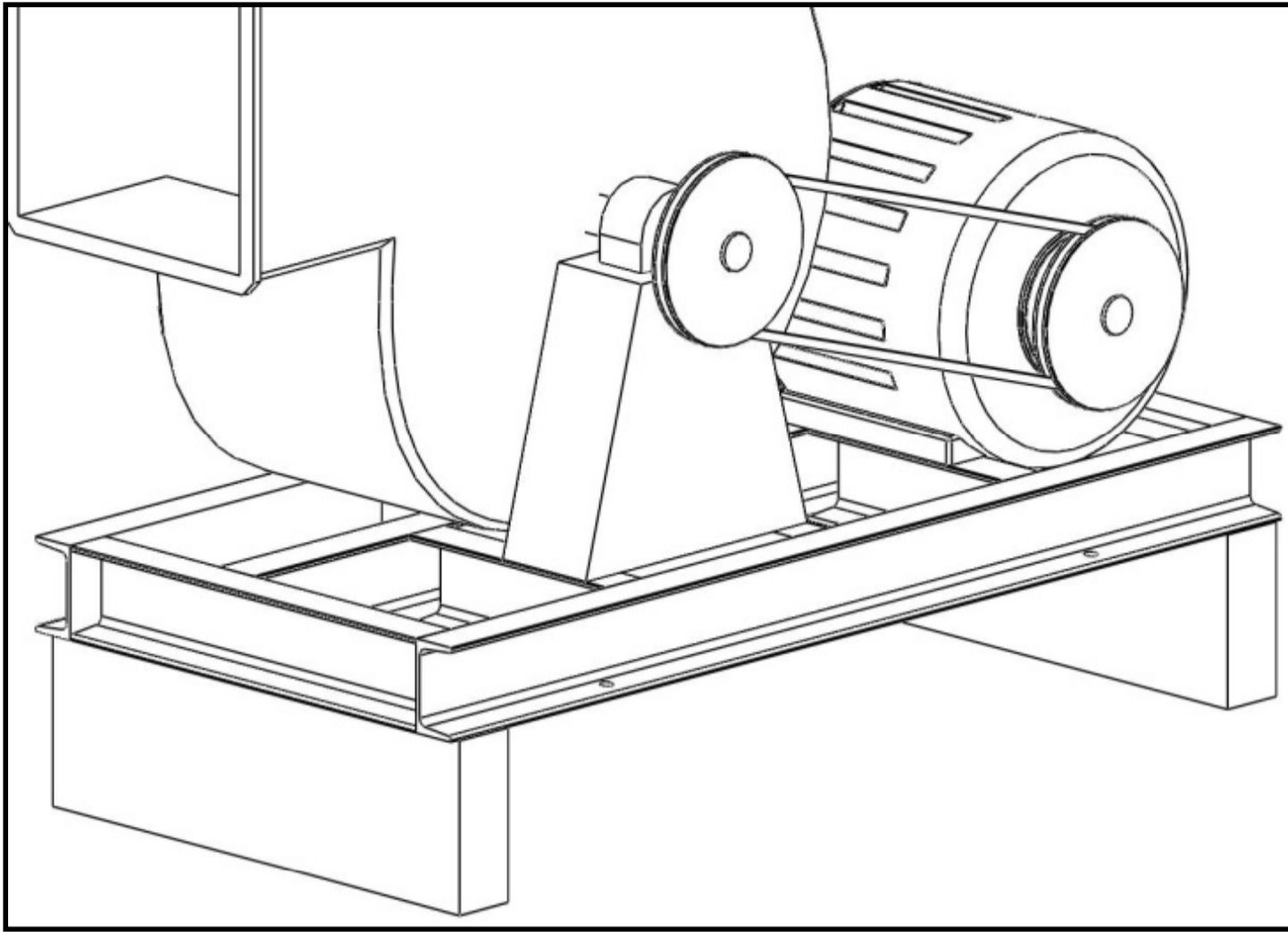

圖3) 將避震器置入安裝機器之位置。

Fig 3) Place the base to the installation location.

JD 型彈簧式避震器圖解說明 JD spring isolator illustration

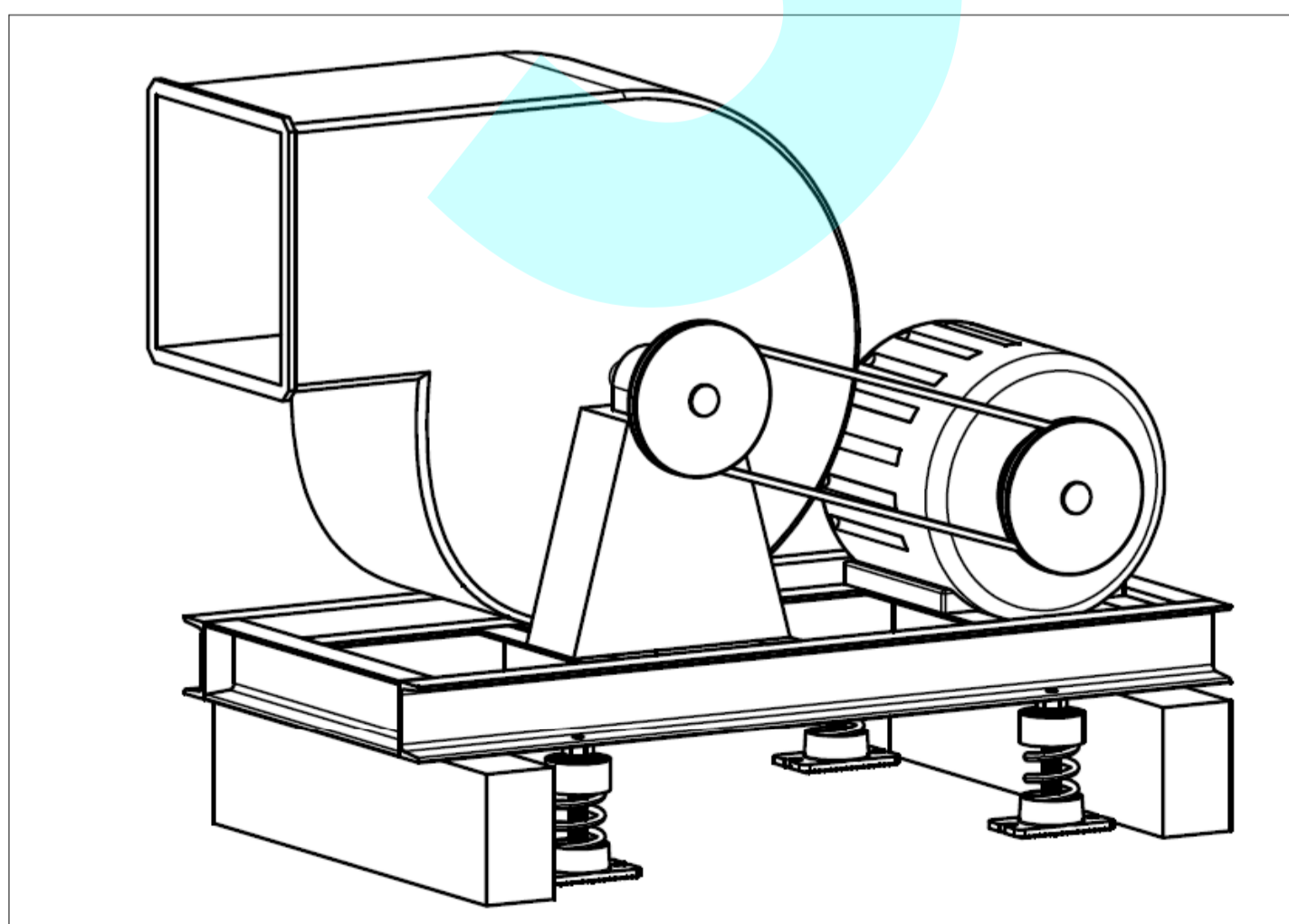
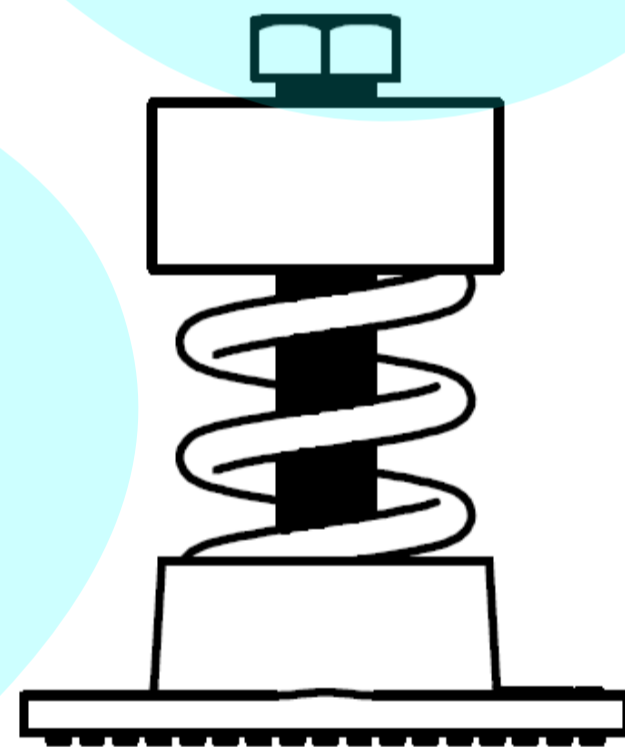

圖4) M12固定螺栓將避震器與基座固定，但不鎖緊。

Fig 4) Fasten the mounts on the base with M12 bolts without locking it.

圖5) 用開口扳手以順時針方向M22調整螺栓，調整至臨時木台可取出時即可停止調整。

Fig 5) Adjust M22 adjustment bolt in the clockwise direction with the open wrench. The adjustment can be stopped once the wooden panel is removed.

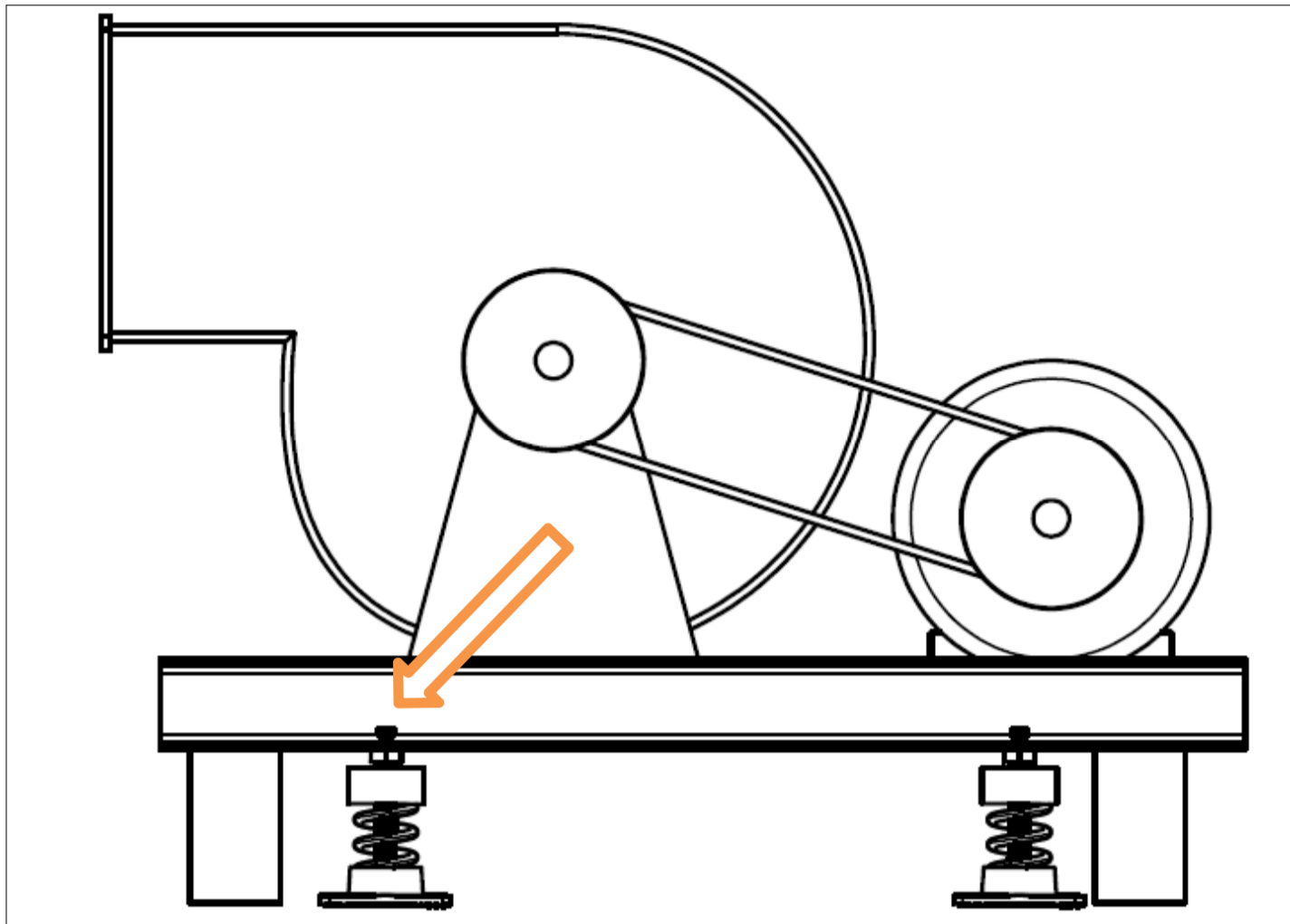
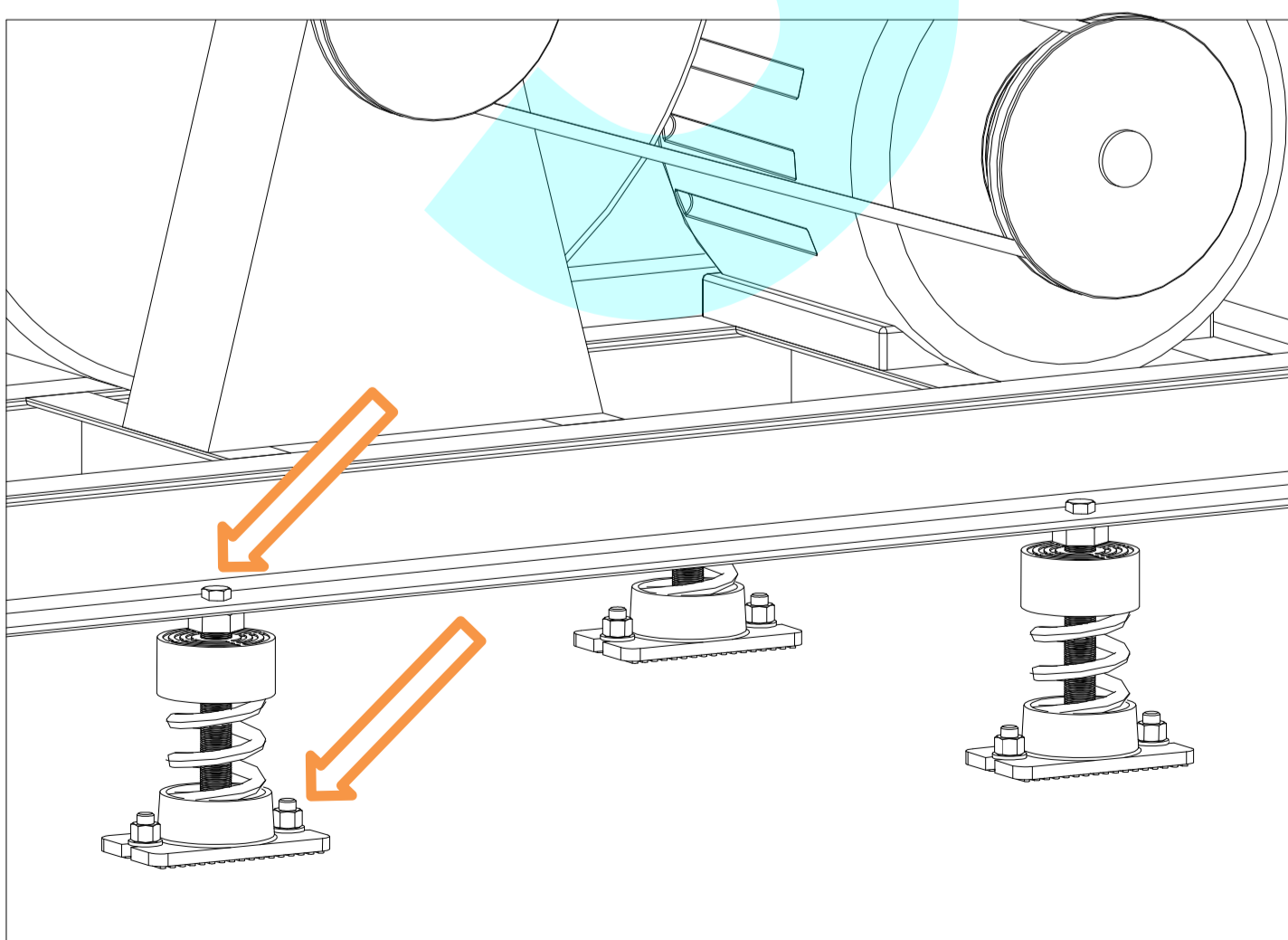
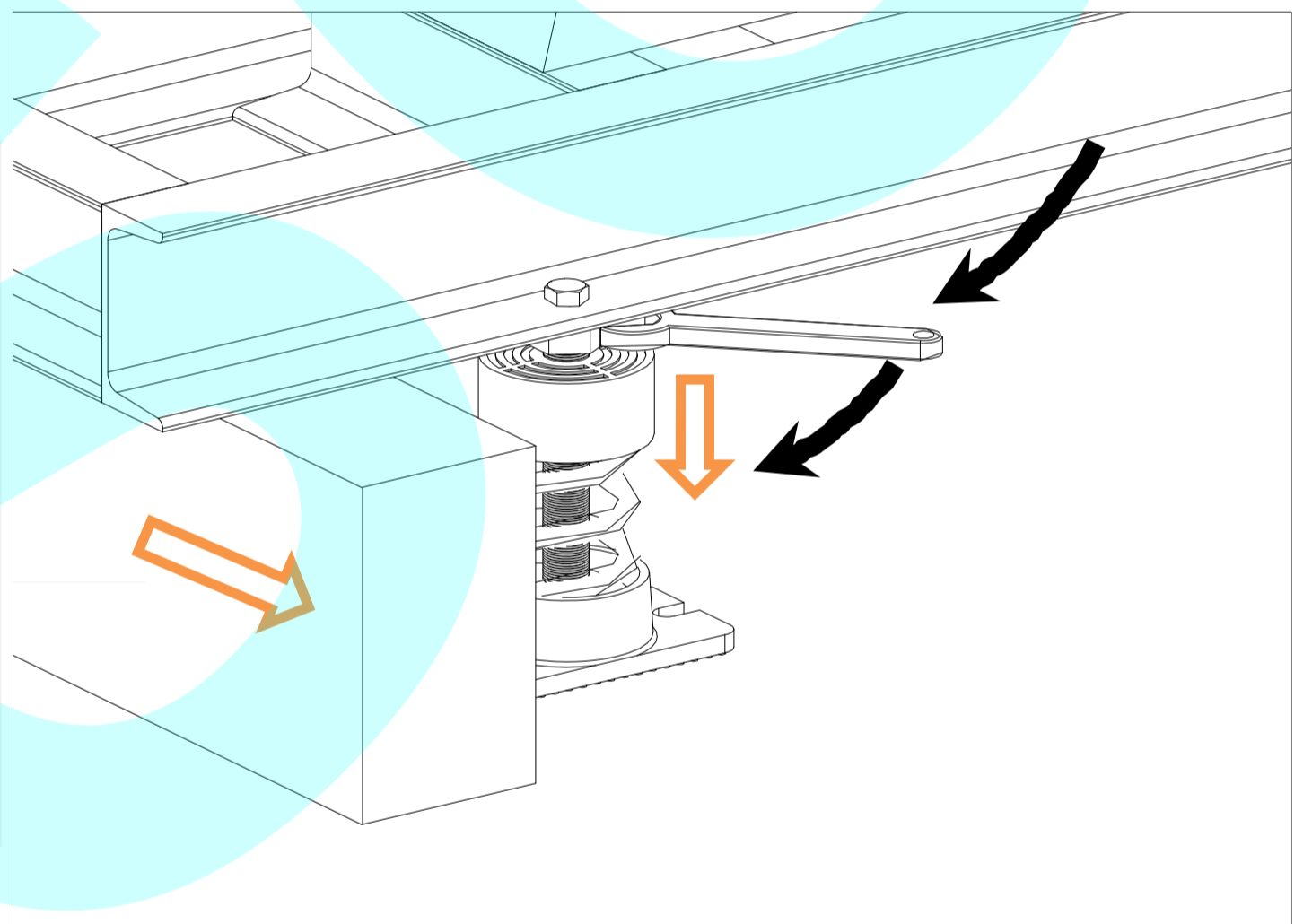

圖6) 將固定螺栓與設備完全鎖緊後，即完成避震器安裝調整。

Fig 6) After the adjustment, lock the mounts with fixed bolts.