

CE 型防振基座安裝說明 CE vibration isolation base installation guide

安裝前，請確認基座之型號規格是否正確。

Before installation, make sure the model and the specification are correct.

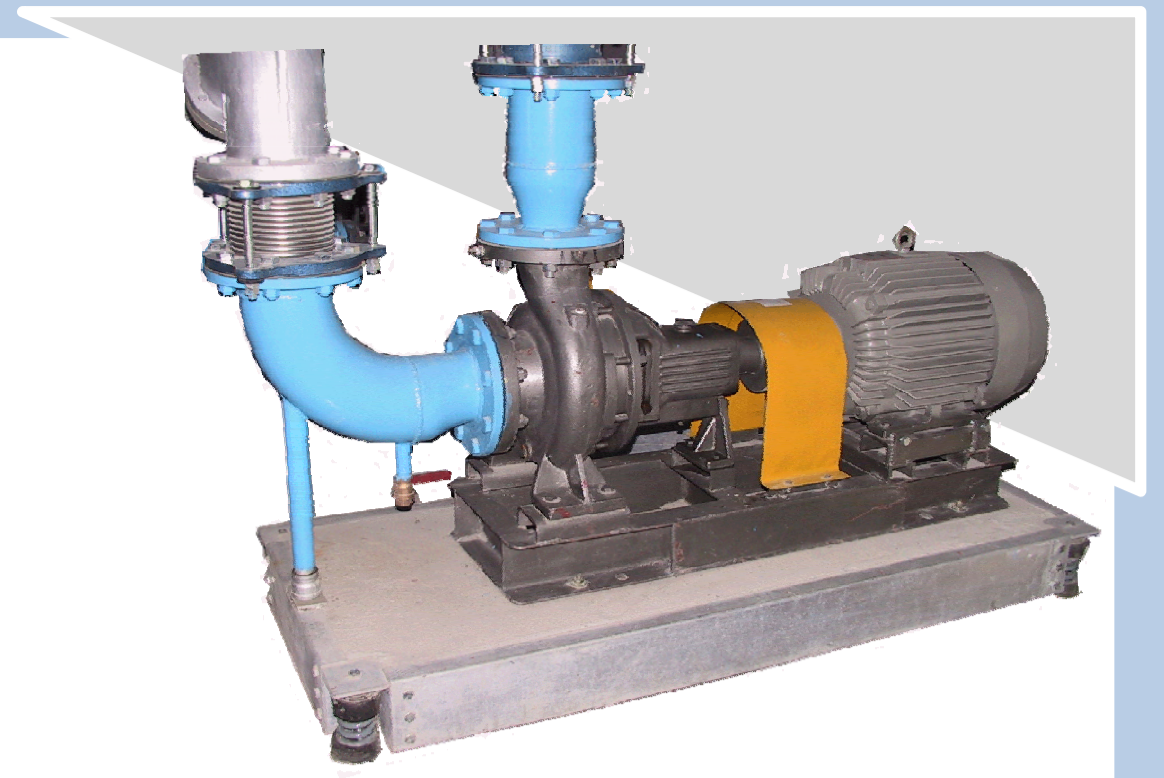

安裝說明

Installation guide

- 所需工具：公制 口徑19mm (M12)、32mm (M22)開口扳手、35mm壓塊、爪式千斤頂。

Required tools: 19mm (M12) and 32mm (M22) open wrenches, 35mm briquet, claw jack.

- 將基座置放於平整地面上、PE布或紙板鋪放於基座下方；將灌漿用塑膠墊塊放置黃色記號處。(如圖1)

Place the base on smooth ground. Place PE cloth or cardboard underneath the base. Place the plastic concrete spacer at yellow marked spots under the rebars..

- 灌混凝土至基座內至完全填滿為止，建議採用3000 psi 以上水泥，基座表面水泥需抹平。(如圖2)

Fill the base fully with concrete (above 3000psi) and level the cement on the surface (Fig 2).

- 水泥未達完全固化強度前，請勿任意搬動基座。

Do not remove the base until the cement reaches completely solidification.

- 基座水泥固化後即可移動至設備安裝位置，並將基座台升高後於基座下方放置35mm高度的壓塊。(如圖3)

Move the base to the installation location after the solidification and place 35mm briquets underneath the base after raising it (Fig 3).

- 將設備安裝固定於基座上，並完成設備的配管工程。(如圖4)

Install and fasten the equipment on the base and complete piping engineering (Fig 4).

- 將JC型避震器置如安裝位置處，以M12固定螺栓將避震器與基座固定，但不鎖緊。(如圖5)

Place JC isolator to its location and fasten it on the base with M12 bolts without locking it (Fig 5).

- 以公制口徑32mm開口扳手以逆時針方向調整M22調整螺栓，使彈簧受力下壓、基座上升；當壓塊可用手力直接取出時即可停止調整，並將壓塊取出。(如圖5)

- Adjust M22 adjustment bolt in the anti-clockwise direction with 32mm open wrench to press down the spring and to raise the base. Adjustment can be stopped once you can take out the briquet (Fig 5).

CE 型防振基座安裝說明 CE vibration isolation base installation guide

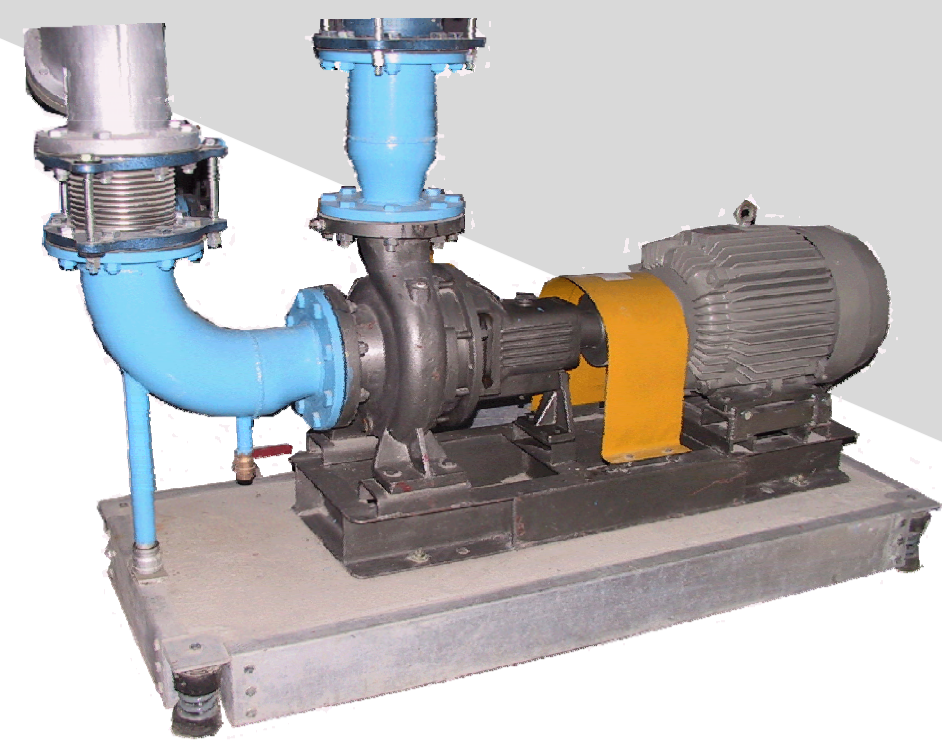

- 調整JC型避震器時需依序均勻調整各個避震器，勿一次調整以保持基座水平。

Adjust each of the isolator in order and evenly while adjusting JC isolator to remain the balance of the base.

- 避震器未完成調整前，壓塊切勿強行取出。

Before completing the adjustment of the isolator, do not force to take out the briquet.

- 調整完成後將M12固定螺栓確實與避震器完全鎖緊，即可完成避震器安裝調整。(如圖6)

After the adjustment, lock the isolator with M12 fixed bolt (Fig 6).

- 安裝後請檢查彈簧之下壓量，如彈簧壓實表示荷重不足無避震效果。應予更換較大荷重loading之規格，並請洽本公司業務人員。

After the adjustment, check the press amount of the spring. If it appears with insufficient loading, please replace with bigger loading by contacting our staff.

- 安裝時，請注意安全。

Be cautious during the installation.

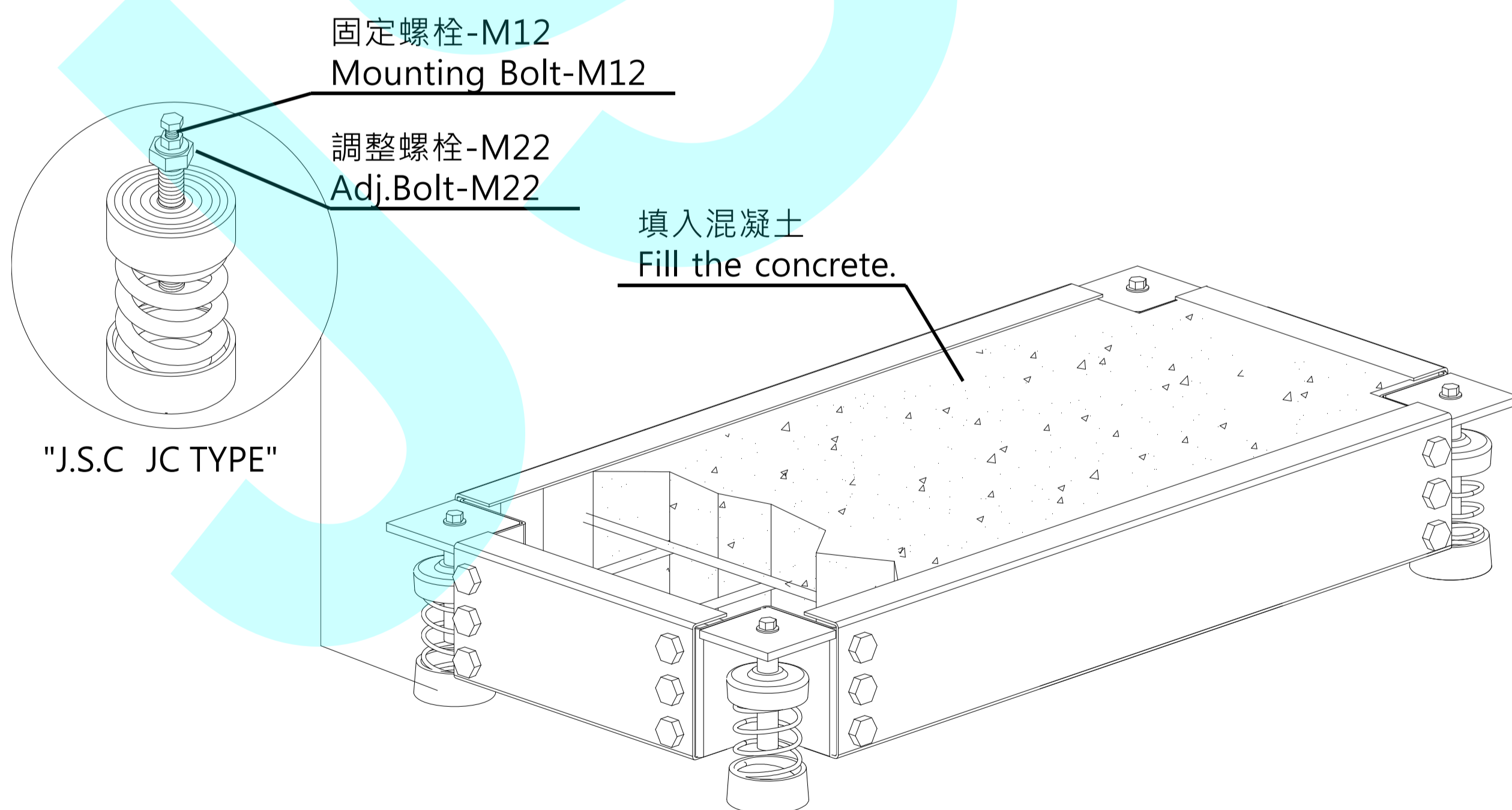

※保養點檢項目：每月觀察M12固定螺栓保持鎖固、保持防振基座&避震器安裝狀態&彈簧下壓撓度正常。

Maintenance checking points: remain M12 fixed bolt locked, balance of the base, installation of the isolator, and the deflection of the spring.

CE 型防振基座安裝說明

CE vibration isolation base installation guide



圖1)將PE布或紙板鋪放於基座下方。將灌漿用塑膠墊塊放置黃色記號處。

Fig 1) Place PE cloth or cardboard underneath the base. Place the plastic concrete spacer at yellow marked spots under the rebars.

圖2)灌混凝土(3000psi以上)至完全填滿為止，基座表面水泥需抹平。(混凝土不得溢出)

Fig 2) Fill the base fully with concrete (above 3000psi). Level the cement on the surface (without spilling).

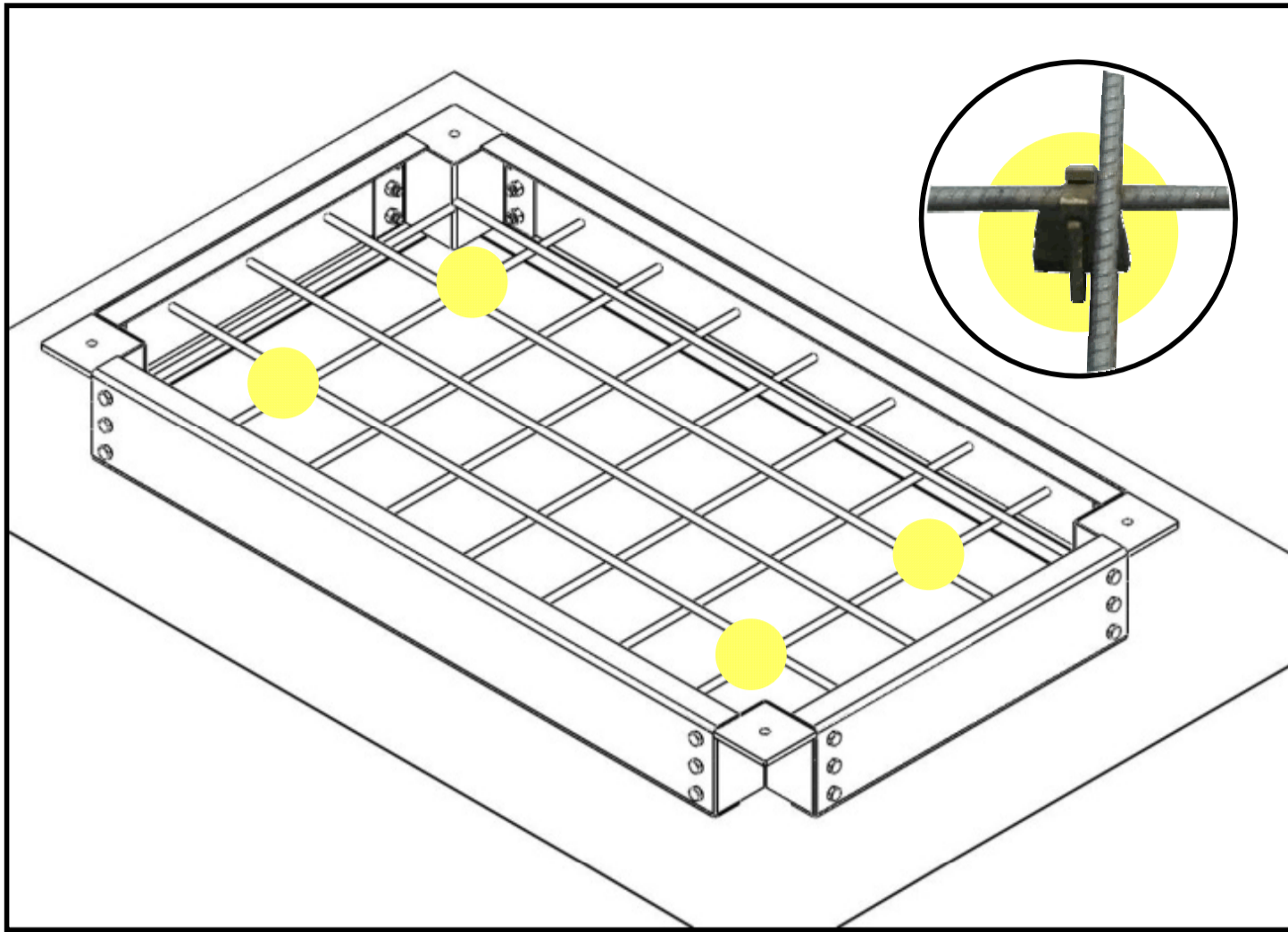

圖3)水泥完全固化後即可將基座放至設備安裝位置處，並於基座下方放置35mm的壓塊數個
Fig 3) Move the base to the installation location after the solidification and place a several 35mm briquets underneath the base.

CE 型防振基座安裝說明 CE vibration isolation base installation guide

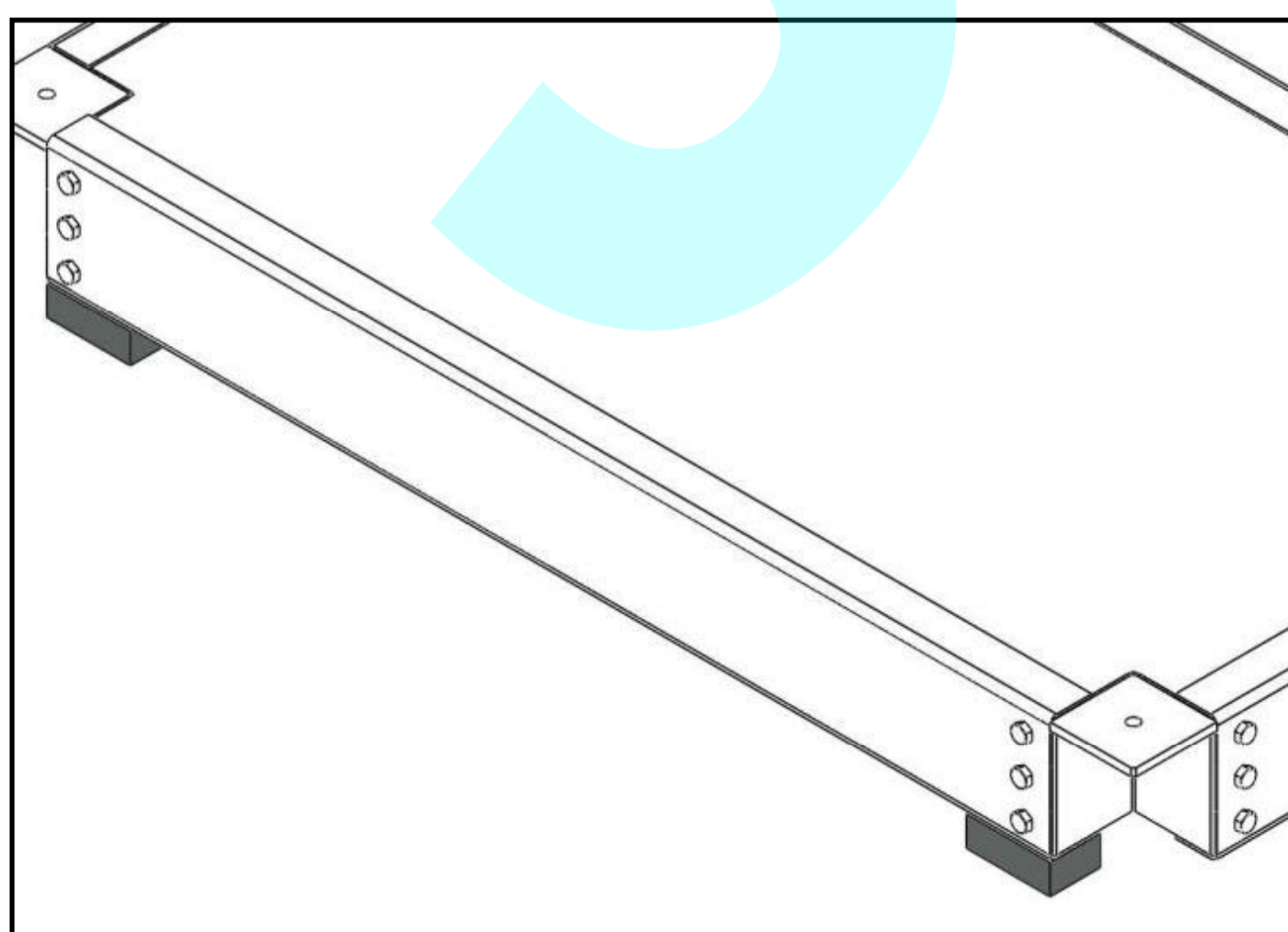
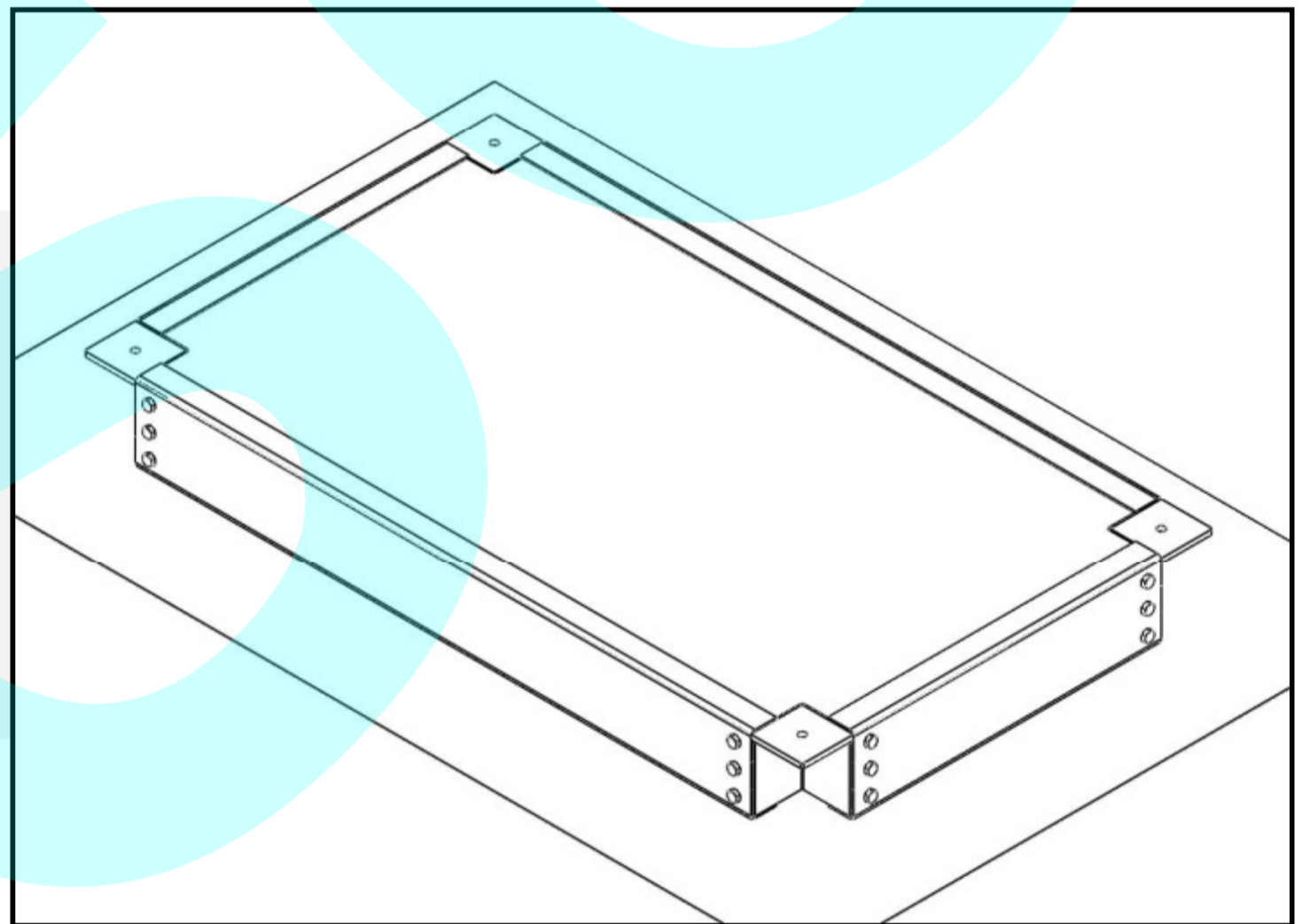

圖4)將設備安裝固定於基座上，並完成設備的配管工程。

Fig 4) Install and fasten the equipment on the base and complete piping engineering.

圖5)避震器置入安裝位置，以開口扳手逆時針方向調整M22調整螺栓，調整至壓塊可取出時，即可停止調整。

Fig 5) Place JC isolator to its location. Adjust M22 adjustment bolt in the anti-clockwise direction with the open wrench. Adjustment can be stopped once you can take out the briquet.

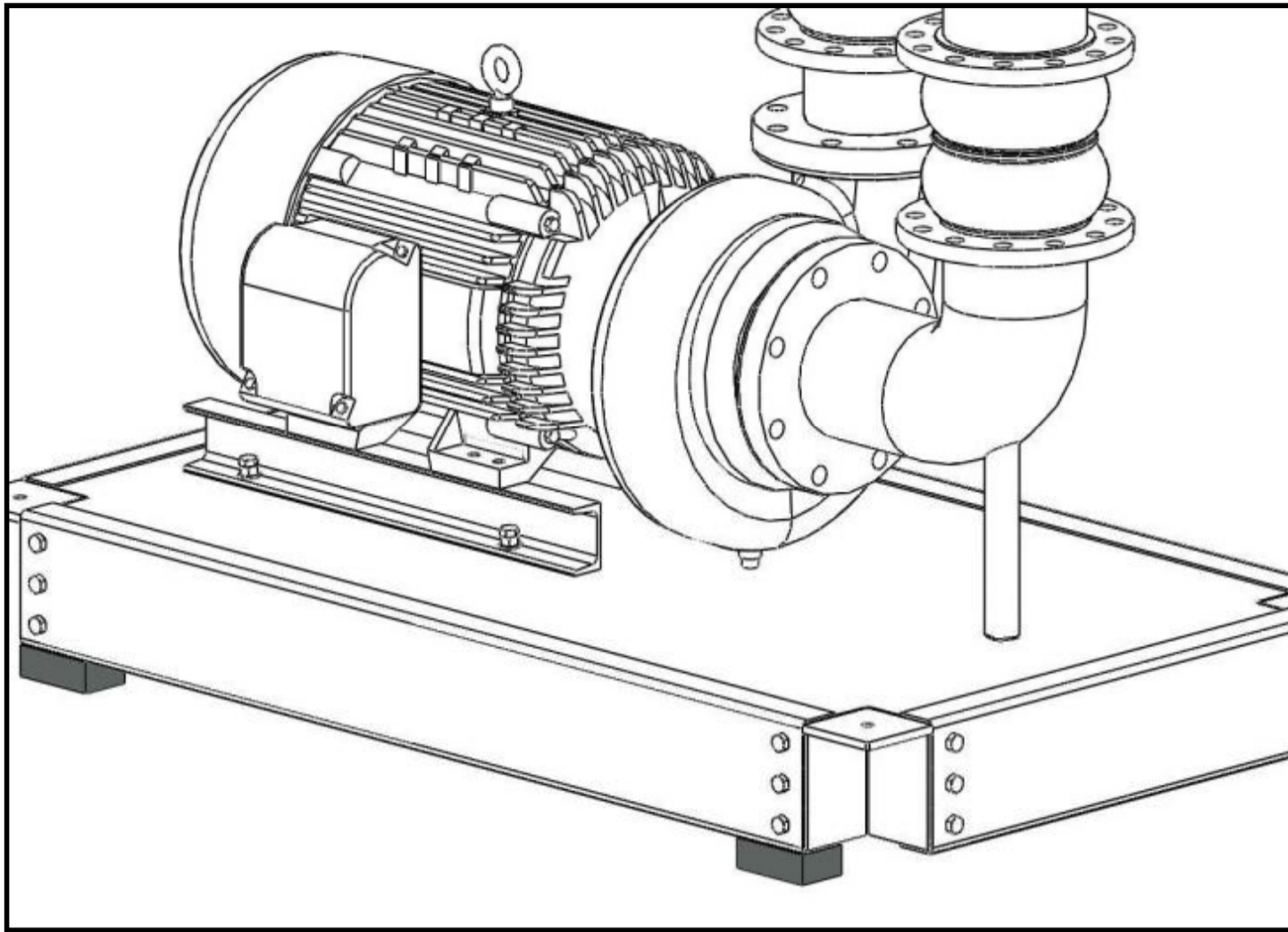
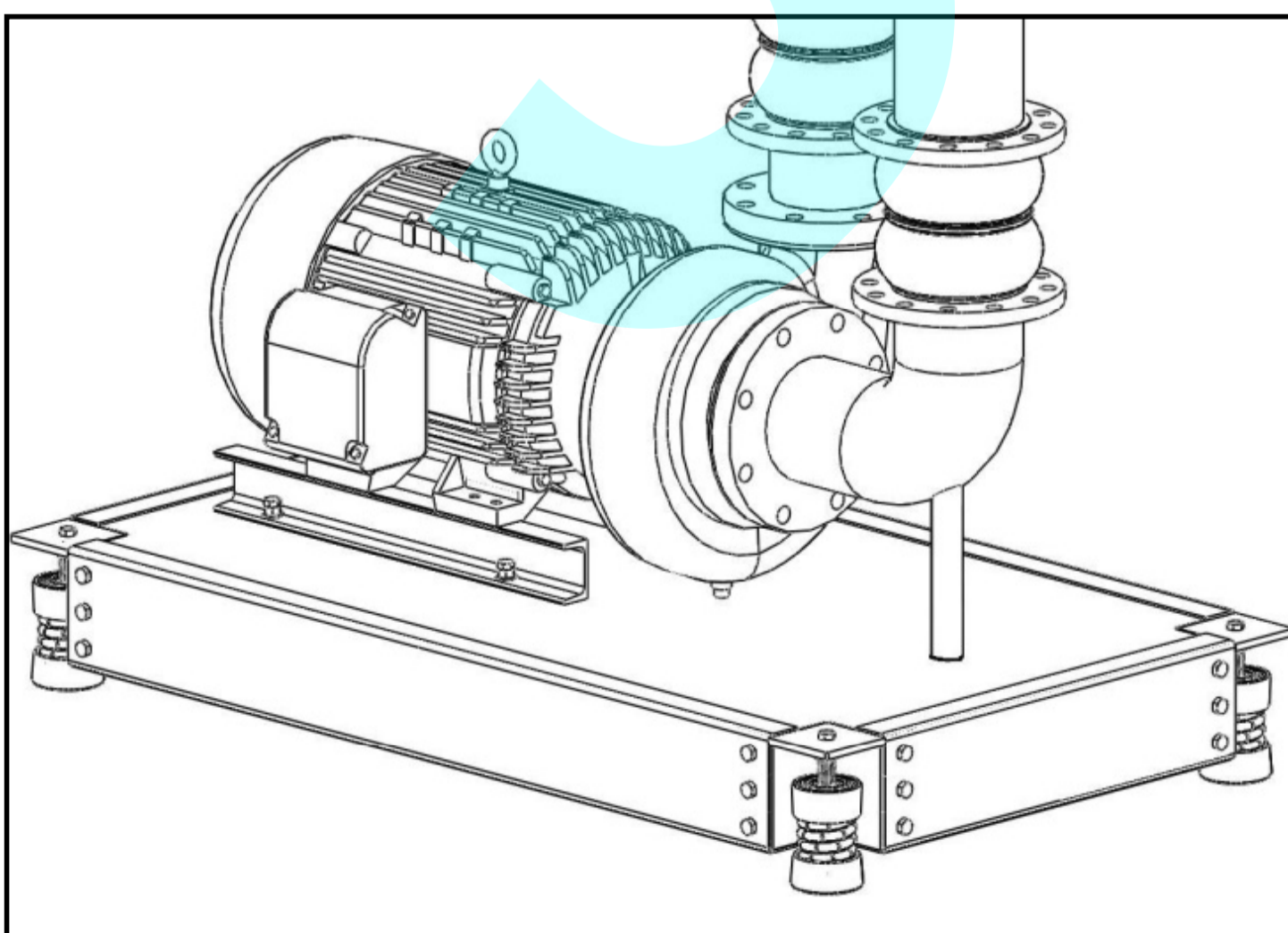
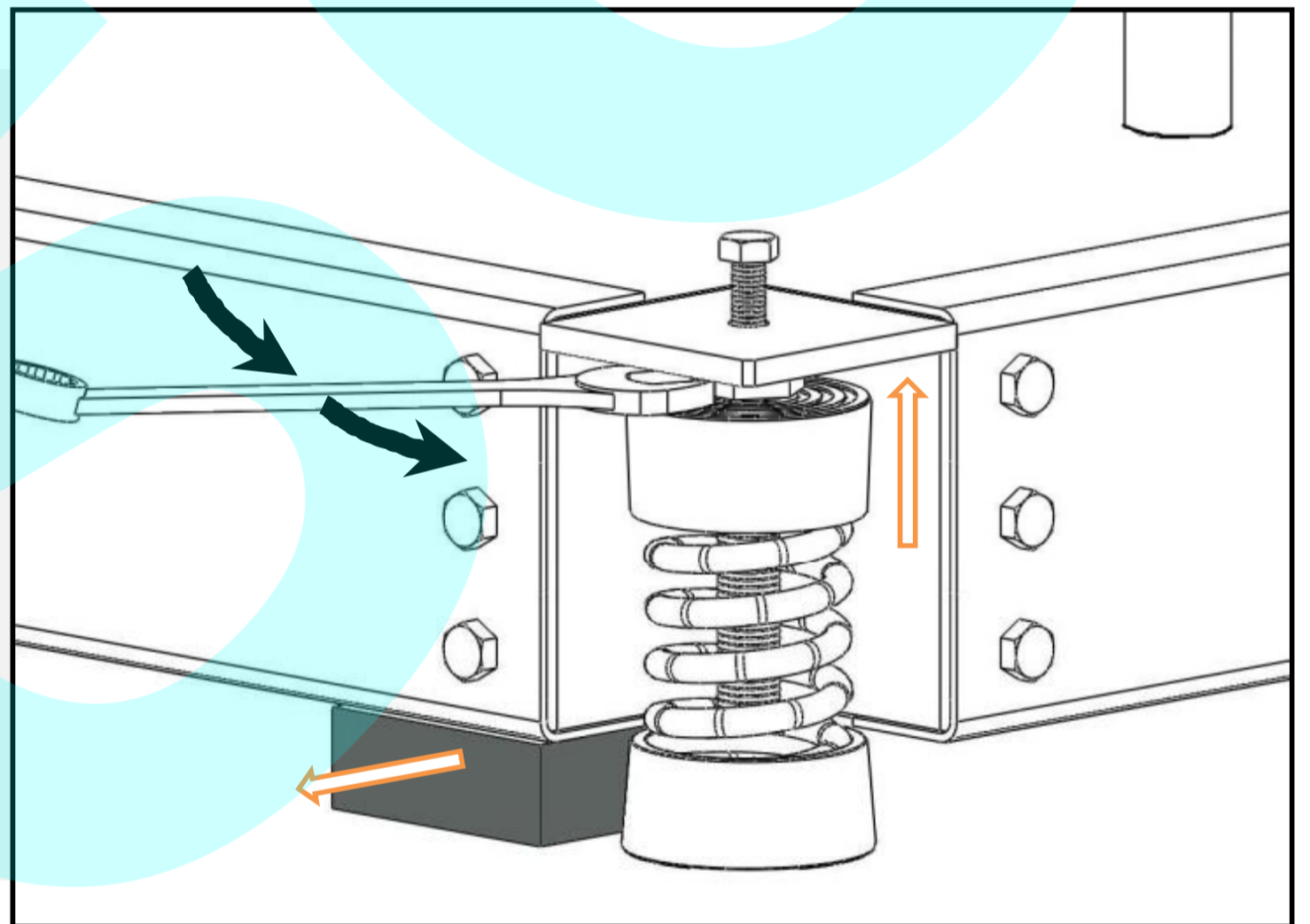

圖6)調整完成後將M12螺栓與避震器完全鎖緊，即可完成避震器安裝調整。

Fig 6) After the adjustment, lock the isolator with M12 fixed bolt.