

# PSR 沖床用避震器安裝說明

## PSR Mounts for press installation guide

安裝前，請確認基座之型號規格是否正確。

Before installation, make sure the model and the specification are correct.



### 安裝說明

### Installation guide

- 所需工具：公制口徑46mm (M30)開口扳手、水平尺、爪式千斤頂。

Required tools: 46mm(M30) open wrench, level bar, and claw jack.

- 安裝前請先將避震器上方的2顆M8螺栓移除。(如圖1)

Remove two M8 bolts above the mounts (Fig 1).

- 以爪式千斤頂慢慢將設備抬高至使臨時木台(110~120 mm)相同高度。(如圖2)

Elevate the equipment with claw jack gradually to the same height as the wooden panel (110~120mm) (Fig 2).

- 將避震器放置於與設備的正確安裝位置。(如圖3)

Place the mounts on the correct location of the equipment (Fig 3).

- 以M30螺栓將避震器與設備固定，但不鎖緊。(如圖4)

Fasten the mounts and the equipment with M30 bolt without locking them (Fig 4).

- 使用公制口徑46mm開手扳手調整M30螺栓以調整避震器高度。(如圖5)

Adjust M30 bolt with 46mm open wrench to adjust the height of the mounts (Fig 5).

- 安裝於設備後，避震器之高度範圍為95~105 mm。

The height of the mounts is between 95~105mm after installing.

- 並以水平尺檢查設備水平，若無水平則調整M30固定調整螺栓來維持水平。

Check the level with level bar and adjust M30 fixed adjustment bolt to maintain the balance.

- 調整完畢後，將M30螺栓確實鎖緊後，即可完成避震器的安裝調整。(如圖6)

Lock M30 bolt to complete the installation (Fig 6).

- 安裝後H高度須大於5mm，若太低請更換荷重能力大的避震器，並請洽本公司業務人員。(如上附圖)

The height of H should be over 5mm. If it appears lower, please replace with bigger loading by contacting our staff (as above fig).

# PSR 沖床用避震器安裝說明

## PSR Mounts for press installation guide

- 安裝時，請注意安全。

Be cautious during the installation.

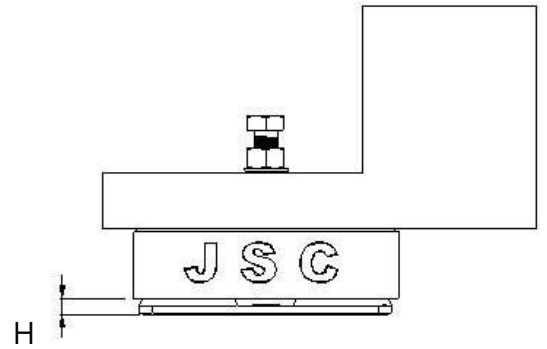
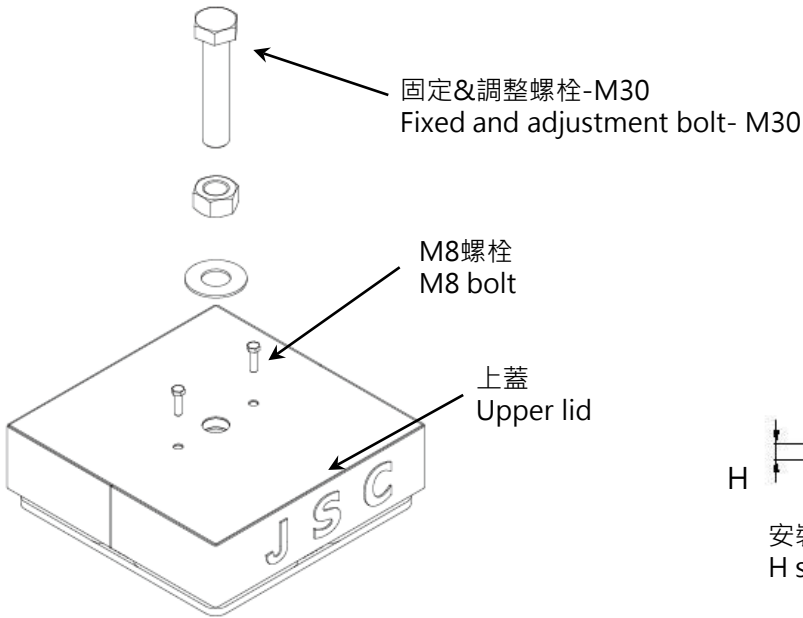

安裝後H處應大於5mm(附圖)  
H should be over 5mm (as above).

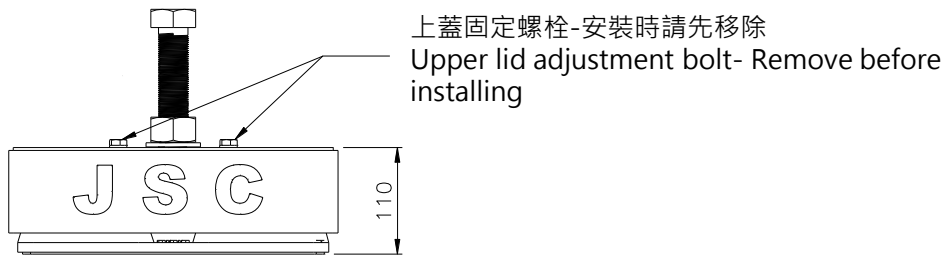
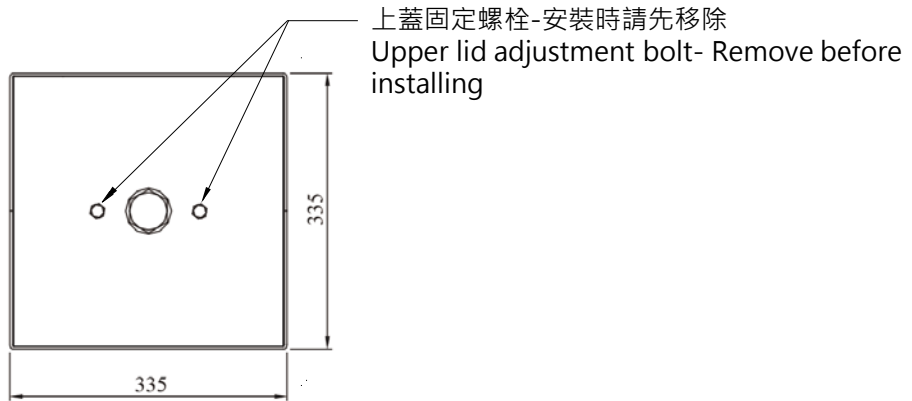

※保養點檢項目：每月觀察固定螺栓保持鎖固、保持避震器安裝狀態&橡膠下壓撓度正常。

Maintenance checking points: check the height of the mounts and maintain the the installation of the mounts and the deflection of the rubber monthly.

# PSR 沖床用避震器圖解說明

## PSR Mounts for press illustration



圖1)安裝前請先將兩顆M8螺栓自避震器上方移除。

Fig 1) Remove two M8 bolts above the mounts.

圖2)利用爪式千斤頂將設備緩慢升起後，於設備底部放置臨時木台。

Fig 2) Elevate the equipment with claw jack gradually and place the wooden panel at the bottom of the equipment.

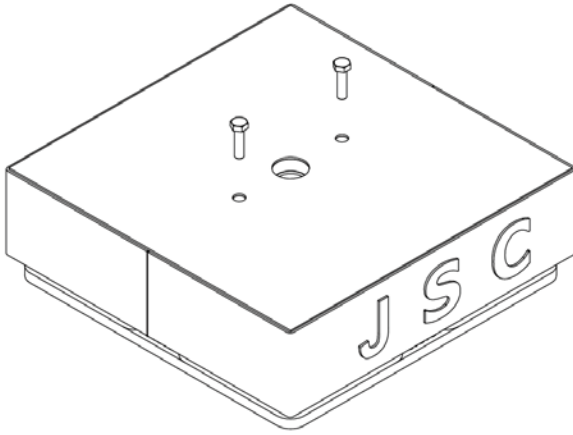

圖3)將避震器放置入安裝位置。

Fig 3) Place the mounts on the installation location.

## PSR 沖床用避震器圖解說明 PSR Mounts for press illustration

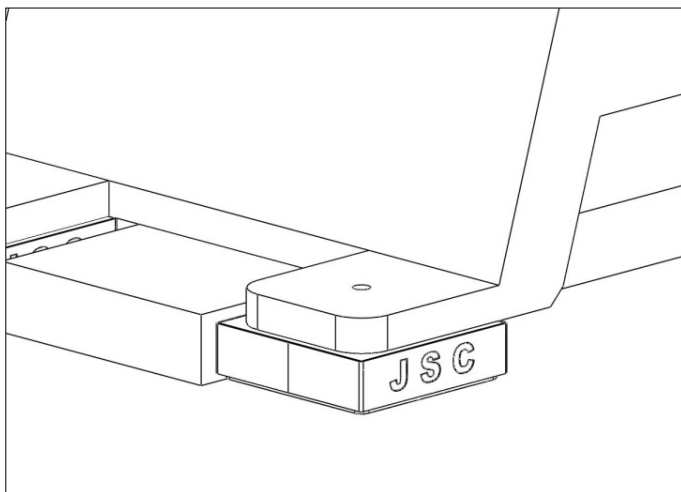
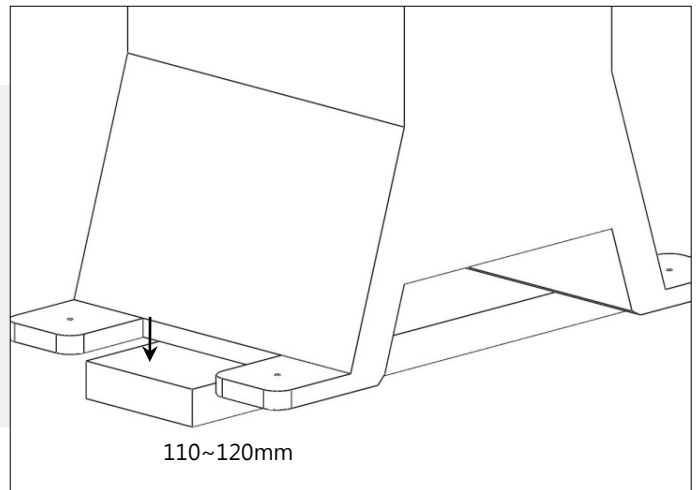

圖4)以M30螺栓將避震器與設備固定，但不鎖緊。

Fig 4) Fasten the mounts and the equipment with M30 bolt without locking them.

圖5)使用46mm開口扳手調整M30螺栓來調整高度，並用水平尺檢查水平度。

Fig 5) Adjust M30 bolt with 46mm open wrench to adjust the height of the mounts.

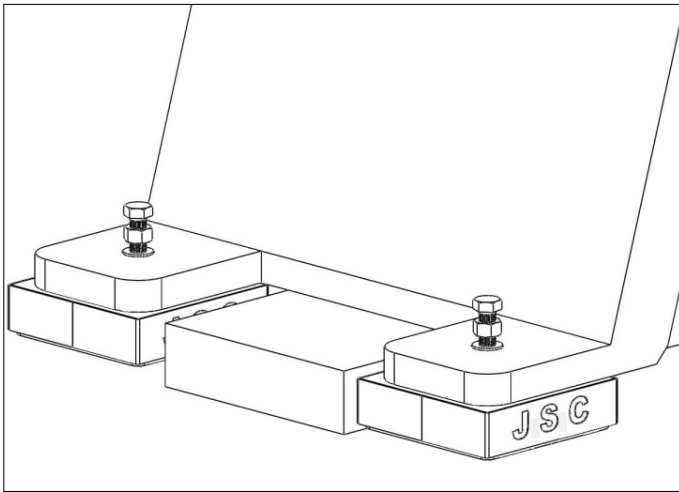

圖6)避震器高度調整完畢後將M30螺栓確實緊，即完成避震器安裝調整。

Fig 6) Lock M30 bolt to complete the installation.

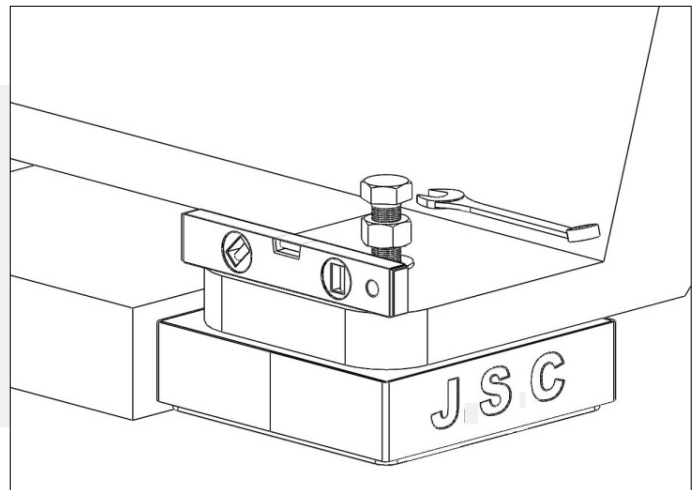